

# **Reference Interconnection Offer**

Samoa Submarine Cable Company Limited

## REFERENCE INTERCONNECT OFFER

This Reference Interconnect Offer (**RIO**) is offered by Samoa Submarine Cable Company Limited (**SSCC**) under section 37 of the *Telecommunications Act 2005* (Samoa) (**Act**).

Capacity and services are offered on the basis of this RIO to service providers licensed by the Office Of The Regulator to operate in Samoa. Section 37 of the Act requires SSCC to include in its RIO the services to be supplied to service providers, the terms and conditions of such supply, and the relevant charges.

Upon acceptance and signing of either the Capacity Purchase Agreement or the Capacity Lease Agreement (attachments to this RIO), that agreement becomes the binding agreement between SSCC and the service provider.

This RIO consists of the following documents:

- Attachment A**      Capacity Purchase Agreement (terms and conditions)
- Attachment B**      Capacity Lease Agreement (terms and conditions)
- Attachment C**      Access Guidelines (colocation and interconnection services)
- Attachment D**      Services and Charges Book

Version: v6

**SAMOA SUBMARINE CABLE COMPANY LIMITED**

**REFERENCE INTERCONNECT OFFER**

**ATTACHMENT A**

**CAPACITY PURCHASE AGREEMENT**

# Capacity Purchase Agreement

Samoa Submarine Cable Company Limited

[Customer name]

# TABLE OF CONTENTS

<b>1.</b>	<b>DEFINITIONS AND INTERPRETATION.....</b>	<b>6</b>
1.1	DEFINITIONS.....	6
1.2	INTERPRETATION .....	10
<b>2.</b>	<b>SALE AND PURCHASE OF CAPACITY..... ERROR! BOOKMARK NOT DEFINED.</b>	
2.1	CONDITION PRECEDENT.....	11
2.2	TERMINATION BEFORE RFS.....	11
<b>3.</b>	<b>SALE AND PURCHASE OF CAPACITY.....</b>	<b>12</b>
3.1	ACQUISITION OF CAPACITY.....	12
3.2	CUSTOMER'S OBLIGATIONS.....	12
3.3	PROGRESS AND ACCEPTANCE TESTING.....	13
<b>4.</b>	<b>CAPACITY AND CONFIGURATION.....</b>	<b>13</b>
4.1	CAPACITY ACTIVATION.....	13
4.2	CABLE INTERFACE.....	13
4.3	INTERRUPTION TO SERVICE.....	14
4.4	MODIFICATIONS TO SSCC NETWORK .....	14
4.5	CAPACITY CHANGES.....	14
4.6	OPERATIONS AND MAINTENANCE .....	15
4.7	ACCESS TO ACCESS POINTS .....	15
<b>5.</b>	<b>CHARGES AND PAYMENT.....</b>	<b>16</b>
5.1	PAYMENTS FOR PURCHASED CAPACITY .....	16
5.2	O&M CHARGE.....	16
5.3	INVOICING.....	16
5.4	PAYMENT DUE DATE .....	16
5.5	EXCLUSIVE OF TAXES.....	17
5.6	NO DEDUCTION FOR WITHHOLDING TAXES.....	17
<b>6.</b>	<b>CONFIDENTIALITY .....</b>	<b>18</b>
6.1	CONFIDENTIALITY OBLIGATION.....	18
6.2	EXCEPTIONS .....	18
6.3	REFERENCE TO CUSTOMER.....	19
6.4	REFERENCE TO SSCC .....	19
<b>7.</b>	<b>REPRESENTATIONS AND WARRANTIES .....</b>	<b>19</b>
7.1	DISCLAIMER .....	19
7.2	WARRANTIES.....	19
<b>8.</b>	<b>TERM AND TERMINATION.....</b>	<b>20</b>
8.1	TERM .....	20
8.2	SUSPENSION AND TERMINATION.....	20

8.3	TERMINATION FOR DETERIORATION.....	20
8.4	REGULATORY EVENT.....	21
8.5	CONSEQUENCES OF SUSPENSION .....	21
8.6	CONSEQUENCES OF TERMINATION .....	22
<b>9.</b>	<b>LIMITATION OF LIABILITY .....</b>	<b>22</b>
9.1	NO LIABILITY FOR CERTAIN EVENTS .....	22
9.2	NO INDIRECT LOSS.....	22
9.3	RESUPPLY OF SERVICES.....	23
9.4	LIMITATION OF LIABILITY.....	23
9.5	EXCEPTIONS TO THE CAP .....	24
<b>10.</b>	<b>INDEMNITY.....</b>	<b>24</b>
<b>11.</b>	<b>FORCE MAJEURE.....</b>	<b>24</b>
<b>12.</b>	<b>ASSIGNMENT .....</b>	<b>25</b>
12.1	RESALE OR ASSIGNMENT BY CUSTOMER.....	25
12.2	ASSIGNMENT BY SSCC .....	25
12.3	SUBCONTRACTING BY SSCC.....	25
<b>13.</b>	<b>GENERAL.....</b>	<b>26</b>
13.1	NOTICES.....	26
13.2	DISPUTES .....	26
13.3	FURTHER ASSURANCE.....	27
13.4	COUNTERPARTS .....	27
13.5	SURVIVABILITY.....	27
13.6	SEVERANCE .....	28
13.7	WHOLE AGREEMENT .....	28
13.8	RELATIONSHIP.....	28
13.9	GOVERNING LAW .....	28

**Schedule 1 - Capacity Purchase Details**

**Schedule 2 - SSCC Network Configuration and Specification**

**Schedule 3 - O&M Charge**

**Schedule 4 - Capacity Unavailability Credits**

**Schedule 5 - Operations and Maintenance Principles**

**DATE**

**PARTIES**

**1. SSCC**

<b>Name</b>	<b>SAMOA SUBMARINE CABLE COMPANY LIMITED</b>
<b>Incorporated in</b>	Samoa
<b>Address</b>	Unit No.203A Gold Star Building, ACC Mall Matefele Apia, Samoa
<b>Senior Representative</b>	
<b>Contact Name</b>	
<b>Contact Details</b>	Mobile Email

**2. Customer**

<b>Name</b>	[Customer name/company number ]
<b>Incorporated in</b>	
<b>Address</b>	
<b>Senior Representative</b>	
<b>Contact Name</b>	
<b>Contact Details</b>	Mobile Email

**BACKGROUND**

- A. SSCC and its related bodies corporate operate the SSCC Network.
- B. The Customer wishes to purchase telecommunications capacity from SSCC.

- C. This Capacity Purchase Agreement sets out the terms and conditions that apply to the provision of telecommunications capacity by SSCC to the Customer.

**IT IS AGREED** as follows.

## **1. Definitions and Interpretation**

---

### **1.1 Definitions**

In this agreement unless the context otherwise requires:

**Acceptance Test Plan** means the document with that title published from time to time by SSCC.

**Access Guidelines** means the document with that title published from time to time by SSCC.

**Access Point** means the location within each of the Facilities specified in Schedule 1 at which the Purchased Capacity is connected.

**Agreement** means this Capacity Purchase Agreement and its schedules and annexures, as varied from time to time.

**Authorisations** means all licences, permits, consents and approvals of any type (including any such authorisations by Government Agencies) required for the Customer to acquire and use the Purchased Capacity.

**Base Price** means the amount specified in item 5 of Schedule 1.

**Business Day** means a day that is not a Saturday, Sunday or public holiday in Apia, Samoa.

**Cable Interface** means the digital/optical input/output ports on the digital/optical distribution frame (excluding the digital/optical distribution frame itself) at the Facility where the Capacity connects with other transmission facilities or equipment, as described in Schedule 2.

**Cable Station** means each of the SSCC Network cable landing stations at (where relevant) Apia (Samoa), Tuasivi (Samoa) and Suva (Fiji).

**Capacity** means capability for carriage of a certain amount of communications by transmission on the SSCC Network and other networks.

**Capacity Activation Date** means each activation date for Purchased Capacity as specified in Schedule 1, as adjusted in accordance with the terms of this Agreement.

**Capacity Payment** means each of the amounts specified in Schedule 1 to be paid by the Customer in accordance with clause 5 on a Capacity Payment Date.

**Capacity Payment Date** means each date specified as a capacity payment date in Schedule 1.

**Capacity Unavailability Credit** has the meaning given to it in Schedule 4.

**Charge** means each fee, charge, cost or payment payable by the Customer to SSCC under this Agreement.

**CIF** means “contract in force”, as that term is commonly understood in the telecommunications submarine cable industry, for the SSCC Network.

**CIF Date** means the date on which CIF is achieved for the SSCC Network.

**Companies Act** means the *Companies Act 2001*.

**Confidential Information** of a party means any information marked as confidential or which by its nature the other party knows or ought to know is confidential (regardless of the form of the information and when it was acquired) and includes trade secrets, technical knowledge, concepts, designs, plans, precedents, processes, methods, techniques, know-how, innovations, ideas, procedures, research data, financial data, databases, personnel data, computer software and programs, customer and supplier information, correspondence and letters and papers of every description including all copies or extracts of same relating to the affairs or business of the party.

**Emergency** means a situation which poses an immediate danger to the health or safety of any person or immediate risk of damage to any network, systems, Facility or other property.

**Facility** means a Cable Station or other location where SSCC permits the Customer’s equipment to connect to the SSCC Network.

**First Capacity Payment** means the Capacity Payment specified as the first capacity payment in Schedule 1.

**Force Majeure Event** means any event that is beyond the reasonable control of a party and which prevents a party from performing, or delays the performance of, any of its obligations under this Agreement including (without limitation):

- (a) any force of nature, act of God, fire, storm or explosion;
- (b) any war, civil disturbance, sabotage, strike, lockout or industrial action;
- (c) any action or inaction by any organ of government or Government Agency or by any third party not under the control of SSCC.

**Government Agency** means any governmental, semi-governmental, administrative, fiscal, judicial or quasi-judicial body, department, commission, authority, tribunal, agency or entity.

**Insolvency Event** means in relation to a party:

- (a) a receiver, liquidator, administrator or similar official is appointed over any of the assets or undertakings of the party;
- (b) the party suspends payment of its debts generally;
- (c) the party is or becomes unable to pay its debts when they are due or is or becomes unable to pay its debts;
- (d) the party enters into or resolves to enter into any arrangement, composition or compromise with, or assignment for the benefit of, its creditors or any class of them;
- (e) the party ceases to carry on business or threatens to cease to carry on business;
- (f) a resolution is passed or any steps are taken to appoint, or to pass a resolution to appoint, an administrator; or
- (g) an application or order is made for the winding up or dissolution of the other party, or a resolution is passed, or any steps are taken to pass a resolution, for the winding up or dissolution of the other party, otherwise than for the purpose of an amalgamation or reconstruction that has the prior written consent of the first party;
- (h) any event which is analogous to an event described in (a) – (g);

(i) a party threatens to do any of (a) – (h).

**IRU** means infeasible right of use.

**Landing Party** means SSCC in Samoa and Fiji International Telecommunications Limited in Fiji.

**O&M Charge** means the charge for operations and maintenance calculated in accordance with Schedule 3.

**Payment Support** means the payment support specified in Schedule 1.

**Prescribed Rate** means the annual rate of 4% above the United States Dollar LIBOR – six months.

**Purchased Capacity** means the unit(s) and configuration(s) of Capacity which is to be delivered to the Customer as specified in Schedule 1.

**Regulatory Event** means:

- (a) a decision or determination by a Government Agency or court of law, or an anticipation by SSCC in its reasonable opinion, that this Agreement or a provision of this Agreement contravenes or may contravene any applicable law or regulation; or
- (b) a refusal by a Government Agency to grant a necessary licence, permit, consent or approval, or a suspension or revocation of a necessary licence, permit, consent or approval, affecting the parties' obligations under this Agreement.

**Representative** of a party includes an employee, agent, officer, director, auditor, advisor, partner, consultant, joint venturer or sub-contractor of that party.

**Resale Restriction Date** means the date which is 24 months after the RFS Date.

**RFS Date** means the date on which SSCC announces that the SSCC Network is ready for commercial service.

**Senior Representative** means a person listed as a senior representative in the Parties section above.

**SSCC Network** means the cable system described in Schedule 2.

**SSCC Network Configuration** means the configuration set out in Schedule 2.

**Total Capacity** means the total amount of Capacity on the SSCC Network which is or can be activated ready for use by a customer of SSCC.

**VAGST** means value added goods and services tax under the law of the Independent State of Samoa.

## **1.2 Interpretation**

Headings are for convenience only and do not affect interpretation.

The following rules of interpretation apply unless the context requires otherwise:

- (a) the singular includes the plural and vice versa;
- (b) a gender includes all genders;
- (c) a reference to dollars or \$ is a reference to United States currency;
- (d) a reference to a person includes a body corporate, an unincorporated body, partnership, firm, trust, joint venture or other entity;
- (e) a reference to a clause, schedule or annexure is to a clause of, or schedule or annexure to, this Agreement;
- (f) a reference to any party to this Agreement or any other agreement or document includes the party's successors and permitted assigns;
- (g) a reference to the words "include", "including", "for example" or "such as" are not used as, nor are they to be interpreted as, words of limitation, and, when introducing an example, do not limit the meaning of the words to which the example relates to that example or examples of a similar kind;
- (h) a reference to conduct includes any omission, statement or undertaking, whether or not in writing;
- (i) a reference to a party is a party to this agreement or any person who executes a deed of accession to this agreement;
- (j) terms defined in the Companies Act have the same meaning in this agreement, unless the context expresses otherwise;

- (k) if any payment by a party under this agreement is due on a day which is not a Business Day, the due date will be the next Business Day in the same calendar month or, if none, the preceding Business Day;
- (l) if an obligation must be performed by two or more persons it binds them jointly and individually.

## **2. Effectiveness of Agreement**

---

### **2.1 Condition Precedent**

This Agreement and the rights, obligations and commitments of the parties under this Agreement (except clauses 2.2(a), 6, 11, 12 and 13, which are effective from the date of this Agreement) are subject to, and conditional in all respects upon, CIF being achieved. If this condition is not satisfied within 12 months from the date of this Agreement then either party may terminate this Agreement on 20 Business Days' notice to the other party.

### **2.2 Termination before RFS**

- (a) The Customer must, within 20 Business Days from the date of this Agreement, deliver to SSCC the Payment Support. If the Customer fails to comply with this obligation, SSCC may terminate this Agreement on 10 Business Days' notice to the Customer.
- (b) If either:
  - (i) SSCC does not announce an RFS Date within 36 months from the date of this Agreement; or
  - (ii) at any time before the RFS Date, SSCC publicly announces that it is not proceeding with the construction of the SSCC Network,

then either SSCC or the Customer may terminate this Agreement by giving 10 Business Days' notice to the other party and SSCC will return to the Customer any Capacity Payments paid by the Customer within 30 Business Days of receipt of the termination notice (the "**refund due date**") and such termination will be without liability for either party (except in relation to the obligation to pay the foregoing refund). If SSCC fails to make payment to the Customer by the refund due date, it must pay interest on the overdue amount at the Prescribed Rate on a daily

basis (compounded monthly) from the refund due date until the payment is received by the Customer.

### **3. Sale and Purchase of Capacity**

---

#### **3.1 Acquisition of Capacity**

- (a) SSCC agrees to grant to the Customer an IRU over the Purchased Capacity from the relevant Capacity Activation Dates and for the remainder of the term of this Agreement, subject to and in accordance with this Agreement.
- (b) The grant of an IRU under paragraph (a) does not give the Customer any property rights to any part of the Purchased Capacity or the SSCC Network.
- (c) Should SSCC, for technical, operational or other reason, decide that the SSCC Network should no longer continue to be operated, nothing in this Agreement will oblige SSCC to continue to operate the SSCC Network. SSCC must notify the Customer of any such decision promptly upon making the decision.

#### **3.2 Customer's Obligations**

The Customer must:

- (a) comply with all reasonable requests and directions made by SSCC in relation to the Purchased Capacity or in relation to the SSCC Network, including in respect of SSCC's legal or regulatory obligations;
- (b) relinquish the Purchased Capacity, at such times as SSCC may reasonably require from time to time, to permit SSCC or another person to make any tests and adjustments, and to perform any maintenance, that may be necessary for that Capacity to be provided efficiently and for the SSCC Network to be maintained in efficient working order;
- (c) obtain and maintain, for the term of this Agreement, all Authorisations;
- (d) make all payments required under this Agreement in full by the date required in this Agreement;
- (e) use the Purchased Capacity in such a way as to not degrade the performance of the SSCC Network, damage any part of the SSCC

Network, or cause interruption or interference to or impairment of any Capacity on the SSCC Network; and

- (f) not use the Purchased Capacity, or permit or authorise the use of the Purchased Capacity, in any manner which may constitute a breach of any applicable law or of any duty or obligation in contract, tort, or otherwise to any third person.

### **3.3 Progress and Acceptance Testing**

- (a) SSCC must keep the Customer informed as to the progress and achievement of the construction of the SSCC Network.
- (b) SSCC will use its reasonable endeavours to give the Customer:
  - (i) no less than one month's notice of the actual RFS Date; and
  - (ii) no less than three months' notice of the month in which the RFS Date will fall.
- (c) Prior to activation of the relevant portion of the Purchased Capacity, SSCC will carry out testing to determine whether the Purchased Capacity is useable for the transmission of communication services, and provide the Customer with the test results and the opportunity to accept or not accept the relevant Purchased Capacity, in accordance with the then current version of the Acceptance Test Plan.

## **4. Capacity and Configuration**

---

### **4.1 Capacity Activation**

The Customer may at any time request SSCC to activate any or all of the Purchased Capacity from the relevant Capacity Activation Date and SSCC will activate the Purchased Capacity in accordance with its applicable activation procedures. Purchased Capacity may only be activated in minimum 10Gbps increments.

### **4.2 Cable Interface**

Subject to interface availability at the time of activation, the Customer is permitted direct interface access in relation to the Purchased Capacity at the Cable Interface.

### **4.3 Interruption to Service**

Subject to SSCC's obligation to pay applicable Capacity Unavailability Credits in accordance with Schedule 4, any part of the Capacity, or the Customer's use of the Purchased Capacity, may be suspended or interrupted for any of the following reasons:

- (a) unplanned fault;
- (b) planned maintenance, upgrade or reconfiguration;
- (c) in the event of an Emergency;
- (d) in order to comply with any applicable law or any requirement of a Government Agency; or
- (e) if the Customer's use of the Purchased Capacity is a threat or risk to the security or proper functioning of any Capacity or any plant or equipment associated with the SSCC Network,

and for the avoidance of doubt the Customer must continue to perform its obligations under this Agreement notwithstanding the suspension and interruption.

### **4.4 Modifications to SSCC Network**

SSCC may, from time to time, add to or vary the SSCC Network Configuration, Facilities or Landing Parties. SSCC will consult with the Customer if SSCC believes that such a change is likely to cause the Customer to incur significant costs in order to change its equipment or to enable it to continue to access the Purchased Capacity. If SSCC proceeds with the change, SSCC must promptly give notice to the Customer and issue a replacement Schedule 1 or Schedule 2 as necessary which will, on issue, be incorporated into and form part of this Agreement.

### **4.5 Capacity Changes**

If, as a result of physical deterioration or a Force Majeure Event, the Total Capacity is or may be reduced, SSCC must use its reasonable endeavours to enforce any warranty rights it may have with its supplier of the SSCC Network in an effort to mitigate the reduction in Total Capacity. If, notwithstanding these efforts, the Total Capacity is reduced, SSCC must promptly give notice to the Customer of the reduction, and may make any amendments to the SSCC

Network Configuration, as are necessary in the circumstances. If, under this clause, the Total Capacity of all users is reduced to an amount below the total amount of Capacity, SSCC may reduce the Purchased Capacity (including Capacity) in the same proportion that the Total Capacity was reduced.

#### **4.6 Operations and Maintenance**

- (a) Where planned maintenance, upgrade or reconfiguration is envisaged, the Customer will be advised, unless circumstances do not permit, 14 days in advance of the timing and expected duration of the interruption. SSCC will use reasonable endeavours to choose the timing to minimise the aggregate impact on all customers after taking into account the operational urgency for the planned activity.
- (b) Should any circumstances arise that are likely to adversely affect availability of the Capacity, SSCC will use its reasonable endeavours to initiate or cause to be initiated maintenance in accordance with SSCC's then current operations and maintenance procedures. SSCC will ensure that its operations and maintenance procedures will be based on and consistent with the operations and maintenance principles set out in Schedule 5.
- (c) SSCC will not be responsible for the operation or maintenance of the Customer-provided equipment or for the transmission or reception of signals by Customer-provided equipment or for the quality of, or defects in, such transmission or reception. The Customer will be solely responsible for the compliance of its own equipment with applicable standards and for obtaining any necessary approvals or authorisations prior to its use.

#### **4.7 Access to Access Points**

- (a) SSCC agrees to provide the Customer with access to the Access Points relevant to the Purchased Capacity (as detailed in Schedule 1) in accordance with the Access Guidelines.
- (b) The Customer agrees to procure and provide safe and uninterrupted access to the Customer's premises, and to any other premises at which the Customer's relevant equipment is located, for SSCC and its employees, suppliers, agents and contractors as necessary for SSCC to make available the Purchased Capacity.

## **5. Charges and Payment**

---

### **5.1 Payments for Purchased Capacity**

The Customer must pay to SSCC:

- (a) the First Capacity Payment for the Purchased Capacity on the later of the CIF Date and the date which is 20 Business Days following execution of this Agreement (and the First Capacity Payment constitutes a debt due to SSCC as from that date); and
- (b) the remaining Capacity Payments for the Purchased Capacity on the Capacity Payment Dates as specified in Schedule 1 (and each remaining Capacity Payment constitutes a debt due to SSCC as from the relevant payment date),

provided however that, if an Insolvency Event occurs in relation to the Customer, then the aggregate of all Capacity Payments as yet unpaid (for the avoidance of doubt, including those which were not yet due) and the associated interest and financing costs (if any) becomes immediately due and payable on the date that the Insolvency Event occurs (and that aggregate amount constitutes a debt due to SSCC as from the date that the Insolvency Event occurs).

### **5.2 O&M Charge**

The Customer must pay the O&M Charge for the operation and maintenance services needed to support availability of the Capacity. The O&M Charge will be invoiced quarterly, starting on the earliest Capacity Activation Date and will be in advance of the period which the O&M Charge covers and shall be due on the first day of such period.

### **5.3 Invoicing**

In the event that a Charge is payable by the Customer to SSCC, SSCC must provide to the Customer an invoice setting out the Charge or Charges. An invoice from SSCC is sufficient evidence of the validity of the Charges contained in the invoice unless it is shown to be incorrect.

### **5.4 Payment Due Date**

- (a) Subject to paragraph (b), an invoice from SSCC is due and payable 20 Business Days from the date that the invoice is received. The

Customer must pay SSCC's invoices on or before the due date by direct bank transfer in available funds to the account specified by SSCC from time to time.

- (b) The Customer must make all payments in full and without deduction, set-off or counterclaim. In the event of a disputed invoice the Customer may only seek resolution of the dispute in accordance with the Dispute Resolution Procedure. If that process establishes that the Customer has made a payment in excess of the amount properly owed then SSCC will refund that excess plus interest on that amount at the Prescribed Rate.
- (c) Any payment not received by SSCC on or before the due date will be deemed overdue and a material breach by the Customer of this Agreement. The Customer must pay interest on the overdue amount at the Prescribed Rate on a daily basis (compounded monthly) from the due date until payment in full is received by SSCC.

#### **5.5 Exclusive of Taxes**

Charges under this Agreement are exclusive of any applicable value added taxes, goods and services taxes, VAGST, or other sales, use, excise, privilege, gross receipts and other taxes, duties, and charges imposed by any governmental authority (excluding those relating to SSCC's income, profit or capital gains). Such taxes, duties and charges (if any) will be charged to and paid by the Customer in addition to the relevant Charge unless the Customer provides SSCC with a valid tax exemption certificate or other evidence reasonably satisfactory to SSCC that the Customer is not subject to such taxes, duties and charges.

#### **5.6 No Deduction for Withholding Taxes**

- (a) If the Customer is required by law to make any deduction or withholding from any payment due to SSCC, the gross amount payable by the Customer to SSCC is increased so that, after any such deduction or withholding for taxes, the net amount received by SSCC will not be less than SSCC would have received had no such deduction or withholding been required.
- (b) If any taxing or governmental authority asserts that the Customer should have made a deduction or withholding for or on account of any taxes with respect to all or a portion of any payments made under this

Agreement, or that SSCC should have collected certain taxes from the Customer which the SSCC did not collect, the Customer will pay SSCC the amount of such taxes (including any interest or penalty on such taxes) such that the amount retained by SSCC in connection with this Agreement net of such taxes, interest and penalties will not be less than SSCC would have retained had those taxes not applied.

## **6. Confidentiality**

---

### **6.1 Confidentiality Obligation**

Each party agrees in relation to the Confidential Information of the other party:

- (a) to keep confidential the Confidential Information for the term of this Agreement and for two years from its expiry or termination;
- (b) to use the Confidential Information solely for the purposes of the performance of its obligations and the exercise of its rights under this Agreement; and
- (c) to disclose the Confidential Information only to those of its employees, advisors, related entities and shareholders who have a need to know (and only to the extent each has a need to know) and who are aware and agree that the Confidential Information must be kept confidential.

### **6.2 Exceptions**

The obligations of confidentiality under this Agreement do not extend to information which (whether before or after this Agreement is executed):

- (a) is disclosed to a party under this Agreement, but at the time of disclosure is rightly known to that party and not subject to an obligation of confidentiality on that party;
- (b) at the time of disclosure is within the public domain or after disclosure comes into the public domain other than by a breach or breaches of any obligation under this clause 6; or
- (c) is required by law or the rules of any securities exchange to be disclosed and the party required to make the disclosure ensures that information is disclosed only to the extent required and not without prior written advice to the other party.

### **6.3 Reference to Customer**

SSCC may refer to the Customer as a customer of SSCC in any press release, marketing, sales or stock exchange reporting materials.

### **6.4 Reference to SSCC**

The Customer may publish objective and factual information relating to any degraded performance or outage affecting the SSCC Network, in accordance with its normal practices for updating customers on the status of the Customer's network.

## **7. Representations and Warranties**

---

### **7.1 Disclaimer**

Each party acknowledges that:

- (a) it has relied on its own enquiries in respect of all matters relating to this Agreement and has not relied on any representation, warranty, condition or statement made by or on behalf of the other party other than as set out in this Agreement; and
- (b) any guarantees, conditions or warranties which may otherwise be implied by law into this Agreement are expressly excluded to the extent permitted by law,

and each party, to the extent permitted by law, releases the other party from all actions, claims, demands and liability (whether or not known) which it may have or claim to have, or but for this release, it might have had against the other party arising out of any representation, warranty, covenant or provision not set out or referred to in this Agreement.

### **7.2 Warranties**

Each party warrants that, as at the date of this Agreement:

- (a) it is a company incorporated in the place of incorporation specified in this Agreement and has full corporate power to enter into and perform this Agreement and has obtained or will by the RFS Date have obtained all necessary approvals, licences, consents and permits to enable it to do so; and

- (b) the entry into and performance of this Agreement by it does not constitute a breach of any obligation (including, without limitation, any statutory, contractual or fiduciary obligation), or default under any agreement or undertaking, by which it is bound.

## **8. Term and Termination**

---

### **8.1 Term**

This Agreement commences on the date that it is executed by both parties and continues until 15 years after the RFS Date, unless terminated earlier in accordance with this Agreement. This Agreement may be renewed for a further term by agreement between the parties and any negotiation of such renewal must be conducted by the parties in good faith.

### **8.2 Suspension and Termination**

SSCC may by giving notice to the Customer terminate this Agreement, or suspend provision of the Purchased Capacity or other services, effective from the date specified in the notice if:

- (a) the Customer fails to pay any amount when due under this Agreement and does not, within 20 Business Days of being requested to do so by notice from SSCC, remedy that failure;
- (b) the Customer materially breaches any other provision of this Agreement and does not, within 10 Business Days of being requested to do so by notice from SSCC, remedy that breach where it is capable of being remedied;
- (c) the Customer materially breaches any provision of this Agreement, which breach is not capable of being remedied; or
- (d) an Insolvency Event occurs in relation to the Customer.

### **8.3 Termination for Deterioration**

SSCC may (but is not obliged to) terminate this Agreement on 12 months' notice, if physical deterioration or a Force Majeure Event has caused the Total Capacity to be reduced substantially or the O&M Charges to be increased substantially on an ongoing basis and SSCC, having used its reasonable endeavours, reasonably determines that it is not economic to remedy, or that

SSCC is otherwise unable to remedy, the reduction in Total Capacity or the increase in O&M Charges.

#### **8.4 Regulatory Event**

If:

- (a) there occurs a Regulatory Event in a particular country or region where SSCC is required to perform an obligation under this Agreement; or
- (b) SSCC is either unable (having made reasonable endeavours) or unwilling (acting reasonably and having regard to SSCC's normal business practices and legitimate commercial interest) to obtain any licence, permit, consent or approval that is or may reasonably be required to perform its obligations under this Agreement,

then, notwithstanding anything else in this Agreement, the parties must meet as soon as practicable and negotiate in good faith such amendments to this Agreement as are necessary or appropriate to ensure that this Agreement does not and will not cause SSCC to contravene any applicable law or regulation, but if the parties do not agree on amendments which will ensure that this Agreement does not and will not cause SSCC to contravene any applicable law or regulation, SSCC may terminate this Agreement by written notice to the Customer.

#### **8.5 Consequences of Suspension**

If provision of the Purchased Capacity is suspended by SSCC in accordance with clause 8.2, SSCC will be entitled, but not obliged to:

- (a) disconnect and prevent the Customer from using the Purchased Capacity;
- (b) continue to charge the Customer for the Purchased Capacity, including O&M Charges and interest on overdue amounts;
- (c) charge a reconnection fee (being not more than the actual cost to SSCC of performing the reconnection) if the suspension by SSCC is lifted and the Purchased Capacity is reinstated.

## **8.6 Consequences of Termination**

- (a) On termination or expiry of this Agreement:
  - (i) the Customer will cease to be entitled to use the Purchased Capacity and the Purchased Capacity will be deemed to have been abandoned by the Customer;
  - (ii) each party may be required by the other party to return, destroy or delete any Confidential Information of the other party in its possession or control.
- (b) In the case of termination under clauses 8.3 and 8.4, SSCC will refund to the Customer any O&M Charges paid in advance for periods falling after the termination date. SSCC is otherwise entitled to retain any Capacity Payments and O&M Charges paid by the Customer and the Customer will not be entitled to any refund of such Charges.
- (c) Termination of this Agreement will be without prejudice to any accrued rights or remedies of either party.

## **9. Limitation of Liability**

---

### **9.1 No Liability for Certain Events**

Subject to SSCC's obligation to pay applicable Capacity Unavailability Credits in accordance with Schedule 4, SSCC will not be liable to the Customer or any of its customers, whether in contract, tort, restitution or otherwise, for any loss, claim, cost or damage (including loss of profit), whether direct, indirect, consequential or special, caused by or arising out of any delay in or failure to activate the Purchased Capacity, breakdown, interruption, degradation, change or variation in the SSCC Network Configuration or Purchased Capacity (whatever is the cause of such delay, failure, breakdown, interruption, degradation, change or variation) however long it lasts.

### **9.2 No Indirect Loss**

Unless expressly stated to the contrary in this Agreement, neither party is liable to the other for any indirect or consequential loss or for any loss of profits, revenue, data, business or opportunity or for any exemplary, special or punitive damages however caused in connection with or related to this Agreement.

### **9.3 Resupply of Services**

Where legislation implies in this Agreement any guarantee, condition or warranty, and that legislation avoids or prohibits provisions in a contract excluding or modifying the application of or exercise of or liability under such guarantee, condition or warranty, the guarantee, condition or warranty is deemed to be included. The liability of SSCC for any breach of such guarantee, condition or warranty is limited, at the option of SSCC, to one or more of the following:

- (a) if the breach relates to goods:
  - (i) the replacement of the goods or the supply of equivalent goods;
  - (ii) the repair of such goods;
  - (iii) the payment of the cost of replacing the goods or of acquiring equivalent goods; or
  - (iv) the payment of the cost of having the products repaired; and
- (b) if the breach relates to services:
  - (i) the supplying of the services again; or
  - (ii) the payment of the cost of having the services supplied again.

### **9.4 Limitation of Liability**

- (a) The liability of SSCC and its Related Bodies Corporate, employees, directors, agents and representatives in respect of all claims made under this Agreement or in relation to the performance by SSCC of its obligations under this Agreement (including in respect of any claims in tort or negligence), and which relates to or is caused by an interruption to any Purchased Capacity, is limited to the specified Capacity Unavailability Credit.
- (b) The total aggregate liability of SSCC and its Related Bodies Corporate, employees, directors, agents and representatives in respect of all claims made under this Agreement or in relation to the performance by SSCC of its obligations under this Agreement (including in respect of any claims in tort or negligence), other than claims which relate to or are caused by an interruption to any Purchased Capacity, is limited to \$100,000.

## **9.5 Exceptions to the cap**

Subject to clause 9.2, nothing in this Agreement will operate so as to limit SSCC's liability to the Customer:

- (a) for death or personal injury caused as a result of SSCC's negligence; or
- (b) for breach by SSCC of its obligations under clause 6 (*Confidentiality*);

## **10. Indemnity**

---

The Customer indemnifies SSCC and its Related Bodies Corporate, directors, officers, employees and agents from and against all losses, damages, liabilities, claims and expenses incurred (including but not limited to reasonable legal costs and defence or settlement costs) arising directly or indirectly as a result of:

- (a) a claim against SSCC by any third person (including a Landing Party) which suffers loss or damage as a result of an act or omission of the Customer or any Related Entity, Representative or customer of the Customer or any representative or customer of a Related Entity of the Customer;
- (b) a claim against SSCC by any third person for infringement of any intellectual property right in respect of telecommunications traffic, calls, data, information or content transmitted by the Customer;
- (c) a claim against SSCC by any third person in relation to the performance or non-performance of, or failure of or interruption to, the Purchased Capacity.

## **11. Force Majeure**

---

- (a) SSCC is not liable for any delay or failure to perform its obligations under this Agreement, and such delay or failure will not be deemed a breach of this Agreement, if such delay or failure arises out of a Force Majeure Event.
- (b) On the occurrence of a Force Majeure Event, SSCC must promptly notify the Customer of the existence of the Force Majeure Event and the cessation or termination of the Force Majeure Event.
- (c) To avoid doubt, the obligation of the Customer to pay O&M Charges under this Agreement will be suspended if a Force Majeure Event

results in an interruption to the Purchased Capacity for more than 60 consecutive days, for the remaining duration of the relevant Force Majeure Event.

## **12. Assignment**

---

### **12.1 Resale or Assignment by Customer**

The Customer may not, with effect on or before the Resale Restriction Date, resell, swap, assign, transfer, novate, mortgage, charge, encumber or otherwise deal with any of its Purchased Capacity or any its rights and obligations under this Agreement, or attempt or purport to do so, without the prior written consent of SSCC (which consent may not be unreasonably withheld or delayed).

### **12.2 Assignment by SSCC**

SSCC may assign, transfer, novate, mortgage, charge, encumber or otherwise deal with any of its rights or obligations under this Agreement to:

- (a) any person which provides financing to SSCC (or any Related Body Corporate of such person), without the Customer's consent;
- (b) any Related Body Corporate of SSCC, without the Customer's consent; or
- (c) any other person, but only with the Customer's consent (which may not be unreasonably withheld or delayed) if the dealing is to be effective on or before to the Resale Restriction Date or without the Customer's consent if the dealing is to be effective after the Resale Restriction Date.

The Customer agrees to execute any documents as may be reasonably necessary to give effect to this clause 12.2 (including without limitation any novation agreement).

### **12.3 Subcontracting by SSCC**

SSCC may subcontract or delegate any of its obligations under this Agreement to any person. For the avoidance of doubt, such subcontracting or delegation will not relieve SSCC from any liability or obligation under this Agreement.

## **13. General**

---

### **13.1 Notices**

- (a) A notice or other communication required or permitted to be given by one party to another must be in writing and:
- (i) delivered personally;
  - (ii) sent by pre-paid mail (by air, if international) to the address of the addressee specified in this Agreement; or
  - (iii) sent by facsimile transmission to the facsimile number of the addressee with acknowledgment of receipt from the facsimile machine of the addressee,
- except that an invoice provided under this Agreement may be delivered by email to the email address of the addressee specified in this Agreement.
- (b) A notice or other communication is taken to have been given:
- (i) if delivered personally, immediately upon delivery;
  - (ii) if mailed to an address within the same country, on the second Business Day after posting;
  - (iii) if mailed to an address within another country, on the tenth Business Day after posting; or
  - (iv) if sent by facsimile or email before 4pm on a Business Day at the place of receipt, on the day it is sent and otherwise on the next Business Day at the place of receipt.
- (c) A party may change its address for service by giving notice of that change in writing to the other party.
- (d) The parties' respective contact details for notification under this Agreement are as set out in the Parties section above.

### **13.2 Disputes**

- (a) A party must not start court proceedings about a dispute arising out of this Agreement unless it first complies with this clause, except:

- (i) where a party seeks urgent injunctive relief; or
  - (ii) where the dispute relates to compliance with this clause.
- (b) A party claiming that a dispute has arisen must notify each other party giving details of the dispute.
  - (c) Each party to the dispute must use its best endeavours to resolve the dispute within five Business Days following receipt of notice of the dispute or a longer period agreed by the parties to the dispute.
  - (d) If the parties do not resolve the dispute under paragraph (c), the chief executive officer or other senior employee of each party must negotiate in good faith to resolve the dispute for a period of up to ten Business Days after the end of the period referred to in paragraph (c).
  - (e) If the dispute is not resolved within the time specified in paragraph (d), or within such further period as the parties agree, then the parties must refer the dispute to mediation in accordance with the Alternative Dispute Resolution Act 2007 (Samoa).

### **13.3 Further Assurance**

Each party will from time to time do all things (including executing all documents) necessary or desirable to give full effect to this Agreement. Each party acknowledges that it has obtained legal advice, or had the opportunity to obtain legal advice, in connection with this Agreement.

### **13.4 Counterparts**

This Agreement may be executed in any number of counterparts each of which constitutes an original and all of which collectively, constitute only one agreement. The signatures of all of the parties need not appear on the same counterpart, and delivery of an executed counterpart signature page by facsimile is as effective as executing and delivering this Agreement in the presence of the other parties to this Agreement. This Agreement is effective upon delivery of one executed counterpart from each party to the other. This clause does not apply if counterpart signing is not required.

### **13.5 Survivability**

- (a) Subject to any provision to the contrary, this Agreement will enure to the benefit of and be binding upon the parties and their successors,

trustees, permitted assigns or receivers but will not enure to the benefit of any other persons.

- (b) The covenants, conditions and provisions of this Agreement which are capable of having effect after the expiry or termination of this Agreement will remain in full force and effect following the expiry or termination of this Agreement.
- (c) Each indemnity in this Agreement survives the expiry or termination of this document.

### **13.6 Severance**

If any part of this Agreement is legally unenforceable, this Agreement does not include it. The remainder of this Agreement continues in full force.

### **13.7 Whole Agreement**

In relation to the subject matter of this Agreement this Agreement is taken to be the whole agreement between the parties and supersedes all oral and written communications by or on behalf of any of the parties in relation to the subject matter of the Agreement.

### **13.8 Relationship**

The parties agree that this Agreement does not create any relationship of partnership or employment, franchise, joint venture or agency and that SSCC is an independent contractor.

### **13.9 Governing Law**

This Agreement is governed by the laws of the Independent State of Samoa. Each party irrevocably submits to the non-exclusive jurisdiction of the courts of the Independent State of Samoa and the courts of appeal from them in respect of any disputes arising under or relating to this Agreement.

## Schedule 1

### Capacity Purchase Details

<b>1. Name of Customer</b>	
----------------------------	--

<b>2. Purchased Capacity</b>	[SEE RIO FOR LIST OF SERVICES AND PRICING AVAILABLE TO CUSTOMERS]
------------------------------	---

<b>3. Segment</b>		
Country A		
Access Point A		
Country B		
Access Point B		

<b>4. RFS Date</b>		9 February 2018
--------------------	--	-----------------

<b>5. Base Price</b>	[SEE RIO FOR LIST OF SERVICES AND PRICING AVAILABLE TO CUSTOMERS]
----------------------	---

<b>6. First Capacity Payment and Capacity Payment Date</b>	
--	--

<b>7. Other Capacity Payments and Capacity Payment Dates</b>	
--	--

<b>8. O&amp;M Charge</b>	To be determined quarterly as per Schedule 3
<b>9. O&amp;M Charge Date</b>	Quarterly in advance

<b>10. Capacity Activation Date(s)</b>	
--	--

<b>11. Payment Support</b>	Bank guarantee in favour of SSCC from a bank with credentials, and on terms, acceptable to SSCC and for an amount not less than the aggregate of the Capacity Payments
----------------------------	--

## **Schedule 2**

### **SSCC Network Configuration and Specification**

[TBA]

### Schedule 3

#### O&M Charge

The O&M Charge for the Customer will be determined at the RFS Date and at the end of the calendar quarter following the RFS Date and at the end of each subsequent calendar quarter, and based on the expected costs for the following quarter (each such quarter being an “O&M period”).

The O&M Charge will be based on the expected aggregated costs for the next O&M period payable by SSCC for:

- x network maintenance charges (including ship standby charges, standby repair charges, planned maintenance and inspection charges, spares storage and other related system costs);
- x Landing Parties and Facilities costs;
- x network operating centre(s) costs;
- x any repairs incurred and not previously recovered, or expected to be incurred; and
- x a 10% administration fee (being 10% of the above charges and costs) payable to SSCC for administrating the various contracts necessary to operate, maintain and repair the SSCC Network.

Any positive balance remaining with SSCC after all payments associated with the previous O&M period’s O&M Charge determination will be offset against then current O&M period’s determination.

Where the actual aggregate costs are more than the expected aggregate costs, any shortfalls will be included in the then current O&M period's determination.

The aggregated cost for each O&M period will be pro-rated across the total activated IRU (purchased) Capacity and total activated lease Capacity on the SSCC Network (as scheduled as at the end of the O&M period) to determine the O&M Charge to be allocated to each customer on the SSCC Network.

The Customer’s O&M Charge will be determined on the following basis:

$$\text{O\&M Charge for an O\&M period (\$)} = \frac{A \times C}{T}$$

where:

- A = the aggregated O&M costs for the SSCC Network for the O&M period (\$)
- C = the Customer's activated Purchased Capacity scheduled as at the end of the O&M period (bps)
- T = the aggregate of total activated IRU (purchased) Capacity and total activated lease Capacity on the SSCC Network scheduled as at the end of the O&M period (bps)

SSCC will keep books, records, receipts and vouchers as may be appropriate and the Customer will have the right to inspect these and other documents relating to the determination of the O&M Charge for an O&M period, so long as the inspection is completed within six months of the issue of the invoice for the O&M Charge being considered. The Customer's rights under this paragraph are subject to the Customer providing reasonable prior notice to SSCC, and subject to the Customer complying with SSCC's reasonable security, access, privacy, confidentiality and safety requirements.

SSCC will provide at the commencement of each O&M period a forecast of the expected O&M Charge for the year commencing at the end of the current upcoming O&M period. The forecast provided will be provided in good faith and with reasonable endeavours by SSCC. SSCC will not be liable for any variations between the forecast provided and the actual O&M Charge which results for the relevant O&M period.

## Schedule 4

### Capacity Unavailability Credits

#### 1 Unavailability

SSCC does not warrant that the Purchased Capacity will be available on an uninterrupted basis, as interruptions may occur outside the control of SSCC. SSCC will nevertheless use reasonable endeavours to ensure that any periods of unavailability are minimised and, in the event of a period of unavailability, may provide to the Customer a credit in accordance with this Schedule (“**Capacity Unavailability Credit**”). The Capacity Unavailability Credits described in this Schedule are the Customer’s sole and exclusive remedies for all matters related to any periods of unavailability. In this Schedule, a month is deemed to begin at 12:00AM Greenwich Mean Time (“**GMT**”) on the first day of a calendar month and end at 12:00AM GMT on the first day of the next calendar month (“**Month**”).

#### 2 Calculation

At the end of a Month in which the Customer requests a Capacity Unavailability Credit, SSCC will calculate the total amount of time that the Customer’s activated Purchased Capacity was unavailable (“**Capacity Unavailability Time**”), based on SSCC’s network records. The Capacity Unavailability Time will be used to determine any Capacity Unavailability Credit. The Capacity Unavailability Credit will be deducted from the O&M Charge in respect of the relevant Month, in the following amounts:

<b>Duration of unavailability of activated Purchased Capacity in the Month (in minutes)</b>	<b>Capacity Unavailability Credit (percentage of the O&amp;M Charge for the Month)</b>
0–216	No credit
217 – 480	5%
Above 480	10%

#### 3 Exclusions

The calculation of Capacity Unavailability Credit amounts will not include periods of any outage or unavailability or other degradation of the Purchased Capacity associated with or caused (in whole or part) by or attributable to any of the following:

- (a) a planned outage;
- (b) planned maintenance during which an outage occurs;
- (c) a cable cut on the SSCC Network (which was not caused by or contributed to by the fault or negligence of SSCC);
- (d) an outage on any non-physically diverse or non-redundant terrestrial section of the SSCC Network;
- (e) an outage on any local access, local loop or domestic backhaul facility ordered directly by the Customer or provided by SSCC on a pass-through basis;
- (f) any act or omission of the Customer or the Customer's agents, contractors, or vendors;
- (g) Customer provided power, equipment or facilities; or
- (h) a Force Majeure Event.

#### **4 Application of credit**

SSCC will calculate the amount of any applicable Capacity Unavailability Credit and deduct this amount from the invoice for the O&M Charge next issued by SSCC after the end of the Month in which the Capacity-affecting event occurred. Capacity Unavailability Credits are calculated after deduction of all discounts and other special pricing arrangements, and may not be applied to governmental fees, taxes, VAGST, surcharges, local access charges or any other charges other than recurring O&M Charges.

#### **5 Other conditions**

If the Customer is entitled to receive more than one Capacity Unavailability Credit due to the same Capacity-affecting event, the Customer will only receive the largest possible credit that it would otherwise be entitled to receive. In no event will the total amount of Capacity Unavailability Credits issued to the Customer for a quarter exceed thirty percent (30%) of the O&M Charge invoiced to the Customer for the affected Capacity for that quarter.

## **Schedule 5**

### **Operations and Maintenance Principles**

[TBA]

**SIGNED** by the parties as an agreement.

**SIGNED** for **Samoa Submarine Cable Company Limited** by its duly authorised representative,  
in the presence of:

---

Signature of witness

---

Signature of representative

---

Name of witness (print)

---

Name/title (print)

**SIGNED** by [ **Customer legal name** ]  
by its duly authorised  
representative,  
in the presence of:

---

Signature of witness

---

Signature of representative

---

Name of witness (print)

---

Name/title (print)

**SAMOA SUBMARINE CABLE COMPANY LIMITED**

**REFERENCE INTERCONNECT OFFER**

**ATTACHMENT B**

**CAPACITY LEASE AGREEMENT**

# Capacity Lease Agreement

Samoa Submarine Cable Company Limited

[ Customer name ]

## TABLE OF CONTENTS

<b>1. DEFINITIONS AND INTERPRETATION.....</b>	<b>6</b>
1.1    DEFINITIONS.....	6
1.2    INTERPRETATION .....	10
<b>2. EFFECTIVENESS OF AGREEMENT.....</b>	<b>11</b>
2.1    CONDITION PRECEDENT.....	11
2.2    TERMINATION BEFORE RFS.....	11
<b>3. LEASED CAPACITY.....</b>	<b>12</b>
3.1    PROVISION OF CAPACITY .....	12
3.2    CUSTOMER’S OBLIGATIONS.....	12
3.3    KEY MILESTONES AND ACCEPTANCE TESTING .....	13
<b>4. CAPACITY AND CONFIGURATION.....</b>	<b>13</b>
4.1    CAPACITY ACTIVATION.....	13
4.2    CABLE INTERFACE.....	13
4.3    INTERRUPTION TO SERVICE.....	14
4.4    MODIFICATIONS TO SSCC NETWORK .....	14
4.5    CAPACITY CHANGES.....	14
4.6    OPERATIONS AND MAINTENANCE .....	15
4.7    ACCESS TO ACCESS POINTS .....	15
<b>5. CHARGES AND PAYMENT.....</b>	<b>16</b>
5.1    PAYMENTS FOR LEASED CAPACITY.....	16
5.2    INVOICING.....	16
5.3    PAYMENT DUE DATE .....	16
5.4    EXCLUSIVE OF TAXES.....	17
5.5    NO DEDUCTION FOR WITHHOLDING TAXES.....	17
<b>6. CONFIDENTIALITY .....</b>	<b>17</b>
6.1    CONFIDENTIALITY OBLIGATION.....	17
6.2    EXCEPTIONS .....	18
6.3    REFERENCE TO CUSTOMER.....	18
6.4    REFERENCE TO SSCC .....	18
<b>7. REPRESENTATIONS AND WARRANTIES .....</b>	<b>18</b>
7.1    DISCLAIMER .....	18
7.2    WARRANTIES.....	19
<b>8. TERM AND TERMINATION.....</b>	<b>19</b>
8.1    TERM AND RENEWAL.....	19
8.2    SUSPENSION AND TERMINATION.....	20
8.3    TERMINATION FOR DETERIORATION OR CARRIER UNAVAILABILITY .....	20

8.4	REGULATORY EVENT.....	21
8.5	CONSEQUENCES OF SUSPENSION .....	21
8.6	CONSEQUENCES OF TERMINATION .....	22
<b>9.</b>	<b>LIMITATION OF LIABILITY .....</b>	<b>22</b>
9.1	NO LIABILITY FOR CERTAIN EVENTS .....	22
9.2	NO INDIRECT LOSS.....	22
9.3	RESUPPLY OF SERVICES.....	23
9.4	LIMITATION OF LIABILITY.....	23
9.5	EXCEPTIONS TO THE CAP .....	24
<b>10.</b>	<b>INDEMNITY.....</b>	<b>24</b>
<b>11.</b>	<b>FORCE MAJEURE.....</b>	<b>24</b>
<b>12.</b>	<b>ASSIGNMENT .....</b>	<b>25</b>
12.1	TRANSFER OR ASSIGNMENT BY CUSTOMER.....	25
12.2	ASSIGNMENT BY SSCC .....	25
12.3	SUBCONTRACTING BY SSCC.....	25
<b>13.</b>	<b>GENERAL.....</b>	<b>25</b>
13.1	NOTICES.....	25
13.2	DISPUTES .....	26
13.3	FURTHER ASSURANCE.....	27
13.4	COUNTERPARTS AND FACSIMILE SIGNATURES .....	27
13.5	SURVIVABILITY.....	27
13.6	SEVERANCE .....	28
13.7	WHOLE AGREEMENT .....	28
13.8	RELATIONSHIP.....	28
13.9	GOVERNING LAW .....	28

**Schedule 1 - Capacity Lease Details**

**Schedule 2 - SSCC Network Configuration and Specification**

**Schedule 3 - Capacity Unavailability Credits**

**Schedule 4 - Special Conditions**

**DATE**

**PARTIES**

**1. SSCC**

<b>Name</b>	<b>SAMOA SUBMARINE CABLE COMPANY LIMITED</b>
<b>Incorporated in</b>	Samoa
<b>Address</b>	Unit Nol. 203A Gold Star Building, ACC Mall Matafele Apia, Samoa
<b>Representative</b>	CEO
<b>Contact Name</b>	
<b>Contact Details</b>	Mobile Email

**2. Customer**

<b>Name</b>	[ Customer name/company number ]
<b>Incorporated in</b>	
<b>Address</b>	
<b>Representative</b>	
<b>Contact Name</b>	
<b>Contact Details</b>	Mobile Email

**BACKGROUND**

- A. SSCC and its related bodies corporate operate the SSCC Network.
- B. The Customer wishes to lease telecommunications capacity from SSCC.

- C. This Capacity Lease Agreement sets out the terms and conditions that apply to the lease of telecommunications capacity by SSCC to the Customer.

**IT IS AGREED** as follows.

## **1. Definitions and Interpretation**

---

### **1.1 Definitions**

In this agreement unless the context otherwise requires:

**Acceptance Test Plan** means the document with that title published from time to time by SSCC.

**Access Guidelines** means the document with that title published from time to time by SSCC.

**Access Point** means the location within each of the Facilities specified in Schedule 1 at which the Leased Capacity is made available to the Customer.

**Agreement** means this Capacity Lease Agreement and its schedules and annexures, as varied from time to time.

**Authorisations** means all licences, permits, consents and approvals of any type (including any such authorisations by Government Agencies) required for the Customer to acquire and use the Leased Capacity.

**Business Day** means a day that is not a Saturday, Sunday or public holiday in Apia, Samoa.

**Cable Interface** means the digital/optical input/output ports on the digital/optical distribution frame (excluding the digital/optical distribution frame itself) at the Facility where the Capacity connects with other transmission facilities or equipment, as described in Schedule 2.

**Cable Station** means each of the SSCC Network cable landing stations at (where relevant) Apia (Samoa), Tuasivi (Samoa) and Suva (Fiji).

**Capacity** means capability for carriage of a certain amount of communications by transmission on the SSCC Network and other networks.

**Capacity Activation Date** means each activation date for Leased Capacity as specified in Schedule 1, as adjusted in accordance with the terms of this Agreement.

**Capacity Payment** means each of the amounts specified in Schedule 1 to be paid by the Customer in accordance with clause 5 on a Capacity Payment Date.

**Capacity Payment Date** means each date specified as a capacity payment date in Schedule 1.

**Capacity Unavailability Credit** has the meaning given to it in Schedule 3.

**Carrier Capacity** means any underlying capacity provided by a third party carrier which must be made available to SSCC in order for SSCC to provide the relevant Leased Capacity.

**Charge** means each fee, charge, cost or payment payable by the Customer to SSCC under this Agreement.

**CIF** means “contract in force”, as that term is commonly understood in the telecommunications submarine cable industry, for the SSCC Network.

**CIF Date** means the date on which CIF is achieved for the SSCC Network.

**Companies Act** means the *Companies Act 2001*.

**Confidential Information** of a party means any information marked as confidential or which by its nature the other party knows or ought to know is confidential (regardless of the form of the information and when it was acquired) and includes trade secrets, technical knowledge, concepts, designs, plans, precedents, processes, methods, techniques, know-how, innovations, ideas, procedures, research data, financial data, databases, personnel data, computer software and programs, customer and supplier information, correspondence and letters and papers of every description including all copies or extracts of same relating to the affairs or business of the party.

**Emergency** means a situation which poses an immediate danger to the health or safety of any person or immediate risk of damage to any network, systems, Facility or other property.

**Facility** means a Cable Station or other location where SSCC permits the Customer’s equipment to connect to the SSCC Network.

**Force Majeure Event** means any event that is beyond the reasonable control of a party and which prevents a party from performing, or delays the performance of, any of its obligations under this Agreement including (without limitation):

- (a) any force of nature, act of God, fire, storm or explosion;
- (b) any war, civil disturbance, sabotage, strike, lockout or industrial action;
- (c) any action or inaction by any organ of government or Government Agency or by any third party not under the control of SSCC.

**Government Agency** means any governmental, semi-governmental, administrative, fiscal, judicial or quasi-judicial body, department, commission, authority, tribunal, agency or entity.

**Initial Lease Term** means each initial lease term specified in Schedule 1.

**Insolvency Event** means in relation to a party:

- (a) a receiver, liquidator, administrator or similar official is appointed over any of the assets or undertaking of the party;
- (b) the party suspends payment of its debts generally;
- (c) the party is or becomes unable to pay its debts when they are due or is or becomes unable to pay its debts;
- (d) the party enters into or resolves to enter into any arrangement, composition or compromise with, or assignment for the benefit of, its creditors or any class of them;
- (e) the party ceases to carry on business or threatens to cease to carry on business;
- (f) a resolution is passed or any steps are taken to appoint, or to pass a resolution to appoint, an administrator; or
- (g) an application or order is made for the winding up or dissolution of the other party, or a resolution is passed, or any steps are taken to pass a resolution, for the winding up or dissolution of the other party, otherwise than for the purpose of an amalgamation or reconstruction that has the prior written consent of the first party;
- (h) any event which is analogous to an event described in (a) – (g);

(i) a party threatens to do any of (a) – (h).

**Landing Party** means SSCC in Samoa and Fiji International Telecommunications Limited in Fiji.

**Leased Capacity** means each unit and configuration of Capacity which is to be made available to the Customer as specified in Schedule 1.

**Payment Support** means the payment support specified in Schedule 1.

**Prescribed Rate** means the annual rate of 4% above the United States Dollar LIBOR – six months.

**Regulatory Event** means:

- (a) a decision or determination by a Government Agency or court of law, or an anticipation by SSCC in its reasonable opinion, that this Agreement or a provision of this Agreement contravenes or may contravene any applicable law or regulation; or
- (b) a refusal by a Government Agency to grant a necessary licence, permit, consent or approval, or a suspension or revocation of a necessary licence, permit, consent or approval, affecting the parties' obligations under this Agreement.

**Renewal Lease Term** means each renewal lease term (if any) specified in Schedule 1.

**Representative** of a party includes an employee, agent, officer, director, auditor, advisor, partner, consultant, joint venturer or sub-contractor of that party.

**RFS Date** means the date on which SSCC announces that the SSCC Network is ready for commercial service.

**Senior Representative** means a person listed as a senior representative in the Parties section above.

**Special Conditions** means the conditions in Schedule 4.

**SSCC Network** means the cable system described in Schedule 2.

**SSCC Network Configuration** means the configuration set out in Schedule 2.

**Term** means the period from the date that this Agreement is executed by both parties and continues until it expires or terminates in accordance with clause 8.

**Total Capacity** means the total amount of Capacity on the SSCC Network which is or can be activated ready for use by a customer of SSCC.

**Transfer Restriction Date** means the date which is 24 months after the RFS Date.

**VAGST** means value added goods and services tax under the law of the Independent State of Samoa.

## **1.2 Interpretation**

Headings are for convenience only and do not affect interpretation.

The following rules of interpretation apply unless the context requires otherwise:

- (a) the singular includes the plural and vice versa;
- (b) a gender includes all genders;
- (c) a reference to dollars or \$ is a reference to United States currency;
- (d) a reference to a person includes a body corporate, an unincorporated body, partnership, firm, trust, joint venture or other entity;
- (e) a reference to a clause, schedule or annexure is to a clause of, or schedule or annexure to, this Agreement;
- (f) a reference to any party to this Agreement or any other agreement or document includes the party's successors and permitted assigns;
- (g) a reference to the words "include", "including", "for example" or "such as" are not used as, nor are they to be interpreted as, words of limitation, and, when introducing an example, do not limit the meaning of the words to which the example relates to that example or examples of a similar kind;
- (h) a reference to conduct includes any omission, statement or undertaking, whether or not in writing;
- (i) a reference to a party is a party to this agreement or any person who executes a deed of accession to this agreement;
- (j) terms defined in the Companies Act have the same meaning in this agreement, unless the context expresses otherwise;

- (k) if any payment by a party under this agreement is due on a day which is not a Business Day, the due date will be the next Business Day in the same calendar month or, if none, the preceding Business Day;
- (l) if an obligation must be performed by two or more persons it binds them jointly and individually.

## **2. Effectiveness of Agreement**

---

### **2.1 Condition Precedent**

This Agreement and the rights, obligations and commitments of the parties under this Agreement (except clauses 2.2(a), 6, 11, 12 and 13, which are effective from the date of this Agreement) are subject to, and conditional in all respects upon, CIF being achieved. If this condition is not satisfied within 12 months from the date of this Agreement then either party may terminate this Agreement on 20 Business Days' notice to the other party.

### **2.2 Termination before RFS**

- (a) The Customer must, within 20 Business Days from the date of this Agreement, deliver to SSCC the Payment Support. If the Customer fails to comply with this obligation, SSCC may terminate this Agreement on 10 Business Days' notice to the Customer.
- (b) If either:
  - (i) SSCC does not announce an RFS Date within 36 months from the date of this Agreement; or
  - (ii) at any time before the RFS Date, SSCC publicly announces that it is not proceeding with the construction of the SSCC Network,

then either SSCC or the Customer may terminate this Agreement by giving 10 Business Days' notice to the other party and SSCC will return to the Customer any Capacity Payments paid by the Customer within 30 Business Days of receipt of the termination notice (the "**refund due date**") and such termination will be without liability for either party (except in relation to the obligation to pay the foregoing refund). If SSCC fails to make payment to the Customer by the refund due date, it must pay interest on the overdue amount at the Prescribed Rate on a daily basis

(compounded monthly) from the refund due date until the payment is received by the Customer.

### **3. Leased Capacity**

---

#### **3.1 Provision of Capacity**

- (a) SSCC agrees to make available to the Customer the Leased Capacity specified in Schedule 1 for the Term, subject to and in accordance with this Agreement.
- (b) The making available of Leased Capacity under paragraph (a) does not give the Customer any property rights to any part of the Leased Capacity or the SSCC Network.
- (c) Should SSCC, for technical, operational or other reason, decide that the SSCC Network should no longer continue to be operated, nothing in this Agreement will oblige SSCC to continue to operate the SSCC Network. SSCC must notify the Customer of any such decision promptly upon making the decision.

#### **3.2 Customer's Obligations**

The Customer must:

- (a) comply with all reasonable requests and directions made by SSCC in relation to the Leased Capacity or in relation to the SSCC Network, including in respect of SSCC's legal or regulatory obligations and any requirements imposed on SSCC and end users in relation to Carrier Capacity;
- (b) relinquish the Leased Capacity, at such times as SSCC may reasonably require from time to time, to permit SSCC or another person to make any tests and adjustments, and to perform any maintenance, that may be necessary for that Capacity to be provided efficiently and for the SSCC Network to be maintained in efficient working order;
- (c) obtain and maintain, for the Term, all Authorisations;
- (d) make all payments required under this Agreement in full by the date required in this Agreement;
- (e) use the Leased Capacity in such a way as to not degrade the performance of the SSCC Network, damage any part of the SSCC

Network, or cause interruption or interference to or impairment of any Capacity on the SSCC Network;

- (f) not use the Leased Capacity, or permit or authorise the use of the Leased Capacity, in any manner which may constitute a breach of any applicable law or of any duty or obligation in contract, tort, or otherwise to any third person; and
- (g) comply with the Special Conditions.

### **3.3 Progress and Acceptance Testing**

- (a) SSCC must keep the Customer informed as to the progress and achievement of the construction of the SSCC Network.
- (b) SSCC will use its reasonable endeavours to give the Customer:
  - (i) no less than one month's notice of the actual RFS Date; and
  - (ii) no less than three months' notice of the month in which the RFS Date will fall.
- (c) Prior to activation of the Leased Capacity, SSCC will carry out testing to determine whether the Leased Capacity is useable for the transmission of communication services and provide the Customer with the test results and the opportunity to accept or not accept the Leased Capacity, in accordance with the then current version of the Acceptance Test Plan.

## **4. Capacity and Configuration**

---

### **4.1 Capacity Activation**

The Customer may at any time request SSCC to activate the Leased Capacity from the Capacity Activation Date and SSCC will activate the Leased Capacity in accordance with its applicable activation procedures.

### **4.2 Cable Interface**

Subject to interface availability at the time of activation, the Customer is permitted direct interface access in relation to the Leased Capacity at the Cable Interface.

### **4.3 Interruption to Service**

Subject to SSCC's obligation to pay applicable Capacity Unavailability Credits in accordance with Schedule 3, any part of the Capacity, or the Customer's use of the Leased Capacity, may be suspended or interrupted for any of the following reasons:

- (a) unplanned fault;
- (b) planned maintenance, upgrade or reconfiguration;
- (c) suspension or interruption of Carrier Capacity;
- (d) in the event of an Emergency;
- (e) in order to comply with any applicable law or any requirement of a Government Agency; or
- (f) if the Customer's use of the Leased Capacity is a threat or risk to the security or proper functioning of any Capacity or any plant or equipment associated with the SSCC Network,

and for the avoidance of doubt the Customer must continue to perform its obligations under this Agreement notwithstanding the suspension and interruption.

### **4.4 Modifications to SSCC Network**

Subject to clause 8.3(c), SSCC may, from time to time, add to or vary the SSCC Network Configuration, Facilities or Landing Parties. SSCC will consult with the Customer if SSCC believes that such a change is likely to cause the Customer to incur significant costs in order to change its equipment or to enable it to continue to access the Leased Capacity. If SSCC proceeds with the change, SSCC must promptly give notice to the Customer and issue a replacement Schedule 1 or Schedule 2 as necessary which will, on issue, be incorporated into and form part of this Agreement.

### **4.5 Capacity Changes**

If, as a result of physical deterioration or a Force Majeure Event, the Total Capacity is or may be reduced, SSCC must use its reasonable endeavours to enforce any warranty rights it may have with its supplier of the SSCC Network in an effort to mitigate the reduction in Total Capacity. If, notwithstanding these efforts, the Total Capacity is reduced, SSCC must promptly give notice to the

Customer of the reduction, and may make any amendments to the SSCC Network Configuration, as are necessary in the circumstances. If, under this clause, the Total Capacity of all users is reduced to an amount below the total amount of Capacity, SSCC may, subject to clause 8.3(c), reduce the Leased Capacity (including Capacity) in the same proportion that the Total Capacity was reduced.

#### **4.6 Operations and Maintenance**

- (a) Where planned maintenance, upgrade or reconfiguration is envisaged, the Customer will be advised, unless circumstances do not permit, 14 days in advance of the timing and expected duration of the interruption. SSCC will use reasonable endeavours to choose the timing to minimise the aggregate impact on all customers after taking into account the operational urgency for the planned activity.
- (b) Should any circumstances arise that are likely to adversely affect availability of the Capacity, SSCC will use its reasonable endeavours to initiate or cause to be initiated maintenance in accordance with SSCC's then current operations and maintenance procedures.
- (c) SSCC will not be responsible for the operation or maintenance of the Customer-provided equipment or for the transmission or reception of signals by Customer-provided equipment or for the quality of, or defects in, such transmission or reception. The Customer will be solely responsible for the compliance of its own equipment with applicable standards and for obtaining any necessary approvals or authorisations prior to its use.

#### **4.7 Access to Access Points**

- (a) SSCC agrees to provide the Customer with access to the Access Points relevant to the Leased Capacity (as detailed in Schedule 1) in accordance with the Access Guidelines.
- (b) The Customer agrees to procure and provide safe and uninterrupted access to the Customer's premises, and to any other premises at which the Customer's relevant equipment is located, for SSCC and its employees, suppliers, agents and contractors as necessary for SSCC to make available the Leased Capacity.

## **5. Charges and Payment**

---

### **5.1 Payments for Leased Capacity**

The Customer must pay to SSCC the Capacity Payments for the Leased Capacity on the Capacity Payment Dates as specified in Schedule 1 (and each Capacity Payment constitutes a debt due to SSCC as from the relevant payment date) provided however that, if an Insolvency Event occurs in relation to the Customer, then the aggregate of all Capacity Payments as yet unpaid (for the avoidance of doubt, including those which were not yet due) and the associated interest and financing costs (if any) becomes immediately due and payable on the date that the Insolvency Event occurs (and that aggregate amount constitutes a debt due to SSCC as from the date that the Insolvency Event occurs).

### **5.2 Invoicing**

In the event that a Charge is payable by the Customer to SSCC, SSCC must provide to the Customer an invoice setting out the Charge or Charges. An invoice from SSCC is sufficient evidence of the validity of the Charges contained in the invoice unless it is shown to be incorrect.

### **5.3 Payment Due Date**

- (a) Subject to paragraph (b), an invoice from SSCC is due and payable 20 Business Days from the date that the invoice is received. The Customer must pay SSCC's invoices on or before the due date by direct bank transfer in available funds to the account specified by SSCC from time to time.
- (b) The Customer must make all payments in full and without deduction, set-off or counterclaim. In the event of a disputed invoice the Customer may only seek resolution of the dispute in accordance with the Dispute Resolution Procedure. If that process establishes that the Customer has made a payment in excess of the amount properly owed then SSCC will refund that excess plus interest on that amount at the Prescribed Rate.
- (c) Any payment not received by SSCC on or before the due date will be deemed overdue and a material breach by the Customer of this Agreement. The Customer must pay interest on the overdue amount at the Prescribed Rate on a daily basis (compounded monthly) from the due date until payment in full is received by SSCC.

#### **5.4 Exclusive of Taxes**

Charges under this Agreement are exclusive of any applicable value added taxes, goods and services taxes, VAGST, or other sales, use, excise, privilege, gross receipts and other taxes, duties, and charges imposed by any governmental authority (excluding those relating to SSCC's income, profit or capital gains). Such taxes, duties and charges (if any) will be charged to and paid by the Customer in addition to the relevant Charge unless the Customer provides SSCC with a valid tax exemption certificate or other evidence reasonably satisfactory to SSCC that the Customer is not subject to such taxes, duties and charges.

#### **5.5 No Deduction for Withholding Taxes**

- (a) If the Customer is required by law to make any deduction or withholding from any payment due to SSCC, the gross amount payable by the Customer to SSCC is increased so that, after any such deduction or withholding for taxes, the net amount received by SSCC will not be less than SSCC would have received had no such deduction or withholding been required.
- (b) If any taxing or governmental authority asserts that the Customer should have made a deduction or withholding for or on account of any taxes with respect to all or a portion of any payments made under this Agreement, or that SSCC should have collected certain taxes from the Customer which the SSCC did not collect, the Customer will pay SSCC the amount of such taxes (including any interest or penalty on such taxes) such that the amount retained by SSCC in connection with this Agreement net of such taxes, interest and penalties will not be less than SSCC would have retained had those taxes not applied.

### **6. Confidentiality**

---

#### **6.1 Confidentiality Obligation**

Each party agrees in relation to the Confidential Information of the other party:

- (a) to keep confidential the Confidential Information for the Term and for two years from the end of the Term;

- (b) to use the Confidential Information solely for the purposes of the performance of its obligations and the exercise of its rights under this Agreement; and
- (c) to disclose the Confidential Information only to those of its employees, advisors, related entities and shareholders who have a need to know (and only to the extent each has a need to know) and who are aware and agree that the Confidential Information must be kept confidential.

## **6.2 Exceptions**

The obligations of confidentiality under this Agreement do not extend to information which (whether before or after this Agreement is executed):

- (a) is disclosed to a party under this Agreement, but at the time of disclosure is rightly known to that party and not subject to an obligation of confidentiality on that party;
- (b) at the time of disclosure is within the public domain or after disclosure comes into the public domain other than by a breach or breaches of any obligation under this clause 6; or
- (c) is required by law or the rules of any securities exchange to be disclosed and the party required to make the disclosure ensures that information is disclosed only to the extent required and not without prior written advice to the other party.

## **6.3 Reference to Customer**

SSCC may refer to the Customer as a customer of SSCC in any press release, marketing, sales or stock exchange reporting materials.

## **6.4 Reference to SSCC**

The Customer may publish objective and factual information relating to any degraded performance or outage affecting the SSCC Network, in accordance with its normal practices for updating customers on the status of the Customer's network.

# **7. Representations and Warranties**

---

## **7.1 Disclaimer**

Each party acknowledges that:

- (a) it has relied on its own enquiries in respect of all matters relating to this Agreement and has not relied on any representation, warranty, condition or statement made by or on behalf of the other party other than as set out in this Agreement; and
- (b) any guarantees, conditions or warranties which may otherwise be implied by law into this Agreement are expressly excluded to the extent permitted by law,

and each party, to the extent permitted by law, releases the other party from all actions, claims, demands and liability (whether or not known) which it may have or claim to have, or but for this release, it might have had against the other party arising out of any representation, warranty, covenant or provision not set out or referred to in this Agreement.

## **7.2 Warranties**

Each party warrants that, as at the date of this Agreement:

- (a) it is a company incorporated in the place of incorporation specified in this Agreement and has full corporate power to enter into and perform this Agreement and has obtained or will by the RFS Date have obtained all necessary approvals, licences, consents and permits to enable it to do so; and
- (b) the entry into and performance of this Agreement by it does not constitute a breach of any obligation (including, without limitation, any statutory, contractual or fiduciary obligation), or default under any agreement or undertaking, by which it is bound.

## **8. Term and Termination**

---

### **8.1 Term and Renewal**

- (a) This Agreement commences on the date that it is executed by both parties and continues until the earlier to occur of (i) termination of this Agreement in accordance with its terms or (ii) the last expiry or termination of any of the Leased Capacity. The Leased Capacity terminates upon this Agreement terminating.
- (b) Each Leased Capacity has the Initial Lease Term and Renewal Lease Term specified in Schedule 1. Except as otherwise provided in this Agreement, the Customer may not terminate or cancel the Initial Lease

Term in respect of each Leased Capacity, but may terminate the Renewal Lease Term in accordance with Schedule 1.

- (c) Following termination of any Leased Capacity, the Customer will cease to be entitled to use the Leased Capacity and the Leased Capacity will be deemed to have been abandoned by the Customer.

## **8.2 Suspension and Termination**

SSCC may by giving notice to the Customer terminate this Agreement, or suspend provision of the Leased Capacity or other services, effective from the date specified in the notice if:

- (a) the Customer fails to pay any amount when due under this Agreement and does not, within 20 Business Days of being requested to do so by notice from SSCC, remedy that failure;
- (b) the Customer materially breaches any other provision of this Agreement and does not, within 10 Business Days of being requested to do so by notice from SSCC, remedy that breach where it is capable of being remedied;
- (c) the Customer materially breaches any provision of this Agreement, which breach is not capable of being remedied; or
- (d) an Insolvency Event occurs in relation to the Customer.

## **8.3 Termination for Deterioration or Carrier Unavailability**

- (a) SSCC may (but is not obliged to) terminate this Agreement on 12 months' notice, if physical deterioration or a Force Majeure Event has caused the Total Capacity to be reduced substantially or the cost to SSCC of operating and maintaining the SSCC Network to be increased substantially on an ongoing basis and SSCC, having used its reasonable endeavours, reasonably determines that it is not economic to remedy, or that SSCC is otherwise unable to remedy, the reduction in Total Capacity or the increase in operations and maintenance costs.
- (b) SSCC may terminate or suspend this Agreement or the Leased Capacity, on notice to the Customer, if any Carrier Capacity is no longer available for any reason.

- (c) If SSCC has exercised its right under clause 4.4 to proceed with a change or its right under clause 4.5 to reduce the Leased Capacity, and such exercise has the result that the Customer is no longer able to enjoy substantially the benefit of the Leased Capacity, the Customer may terminate this Agreement on 40 Business Days' notice.

#### **8.4 Regulatory Event**

If:

- (a) there occurs a Regulatory Event in a particular country or region where SSCC is required to perform an obligation under this Agreement; or
- (b) SSCC is either unable (having made reasonable endeavours) or unwilling (acting reasonably and having regard to SSCC's normal business practices and legitimate commercial interest) to obtain any licence, permit, consent or approval that is or may reasonably be required to perform its obligations under this Agreement,

then, notwithstanding anything else in this Agreement, the parties must meet as soon as practicable and negotiate in good faith such amendments to this Agreement as are necessary or appropriate to ensure that this Agreement does not and will not cause SSCC to contravene any applicable law or regulation, but if the parties do not agree on amendments which will ensure that this Agreement does not and will not cause SSCC to contravene any applicable law or regulation, SSCC may terminate this Agreement by written notice to the Customer.

#### **8.5 Consequences of Suspension**

If the Leased Capacity is suspended by SSCC in accordance with clause 8.2, SSCC will be entitled, but not obliged to:

- (a) disconnect and prevent the Customer from using the Leased Capacity;
- (b) continue to charge the Customer for the Leased Capacity for the remainder of the Term, including interest on overdue amounts;
- (c) charge a reconnection fee (being not more than the actual cost to SSCC of performing the reconnection) if the suspension by SSCC is lifted and the Leased Capacity is reinstated.

## **8.6 Consequences of Termination**

- (a) On termination or expiry of this Agreement:
  - (i) the Customer will cease to be entitled to use the Leased Capacity and the Leased Capacity will be deemed to have been abandoned by the Customer;
  - (ii) each party may be required by the other party to return, destroy or delete any Confidential Information of the other party in its possession or control.
- (b) In the case of termination under clauses 8.3 and 8.4, SSCC will refund to the Customer any Capacity Payments paid in advance for periods falling after the termination date. SSCC is otherwise entitled to retain any Capacity Payments paid by the Customer and the Customer will not be entitled to any refund of such Charges.
- (c) Termination of this Agreement will be without prejudice to any accrued rights or remedies of either party.

## **9. Limitation of Liability**

---

### **9.1 No Liability for Certain Events**

Subject to SSCC's obligation to pay applicable Capacity Unavailability Credits in accordance with Schedule 3, SSCC will not be liable to the Customer or any of its customers, whether in contract, tort, restitution or otherwise, for any loss, claim, cost or damage (including loss of profit), whether direct, indirect, consequential or special, caused by or arising out of any delay in or failure to activate the Leased Capacity, breakdown, interruption, degradation, change or variation in the SSCC Network Configuration or Leased Capacity (whatever is the cause of such delay, failure, breakdown, interruption, degradation, change or variation) however long it lasts.

### **9.2 No Indirect Loss**

Unless expressly stated to the contrary in this Agreement, neither party is liable to the other for any indirect or consequential loss or for any loss of profits, revenue, data, business or opportunity or for any exemplary, special or punitive damages however caused in connection with or related to this Agreement.

### **9.3 Resupply of Services**

Where legislation implies in this Agreement any guarantee, condition or warranty, and that legislation avoids or prohibits provisions in a contract excluding or modifying the application of or exercise of or liability under such guarantee, condition or warranty, the guarantee, condition or warranty is deemed to be included. The liability of SSCC for any breach of such guarantee, condition or warranty is limited, at the option of SSCC, to one or more of the following:

- (a) if the breach relates to goods:
  - (i) the replacement of the goods or the supply of equivalent goods;
  - (ii) the repair of such goods;
  - (iii) the payment of the cost of replacing the goods or of acquiring equivalent goods; or
  - (iv) the payment of the cost of having the products repaired; and
- (b) if the breach relates to services:
  - (i) the supplying of the services again; or
  - (ii) the payment of the cost of having the services supplied again.

### **9.4 Limitation of Liability**

- (a) The liability of SSCC and its Related Bodies Corporate, employees, directors, agents and representatives in respect of any claim made under this Agreement or in relation to the performance by SSCC of its obligations under this Agreement (including in respect of any claims in tort or negligence), and which relates to or is caused by an interruption to any Leased Capacity, is limited to the specified Capacity Unavailability Credit.
- (b) The total aggregate liability of SSCC and its Related Bodies Corporate, employees, directors, agents and representatives in respect of all claims made under this Agreement or in relation to the performance by SSCC of its obligations under this Agreement (including in respect of any claims in tort or negligence), other than claims which relate to or are caused by an interruption to any Leased Capacity, is limited to \$100,000.

## **9.5 Exceptions to the cap**

Subject to clause 9.2, nothing in this Agreement will operate so as to limit SSCC's liability to the Customer:

- (a) for death or personal injury caused as a result of SSCC's negligence; or
- (b) for breach by SSCC of its obligations under clause 6 (*Confidentiality*);

## **10. Indemnity**

---

The Customer indemnifies SSCC and its Related Bodies Corporate, directors, officers, employees and agents from and against all losses, damages, liabilities, claims and expenses incurred (including but not limited to reasonable legal costs and defence or settlement costs) arising directly or indirectly as a result of:

- (a) a claim against SSCC by any third person (including a Landing Party) which suffers loss or damage as a result of an act or omission of the Customer or any Related Entity, Representative or customer of the Customer or any representative or customer of a Related Entity of the Customer;
- (b) a claim against SSCC by any third person for infringement of any intellectual property right in respect of telecommunications traffic, calls, data, information or content transmitted by the Customer;
- (c) a claim against SSCC by any third person in relation to the performance or non-performance of, or failure of or interruption to, the Leased Capacity.

## **11. Force Majeure**

---

- (a) SSCC is not liable for any delay or failure to perform its obligations under this Agreement, and such delay or failure will not be deemed a breach of this Agreement, if such delay or failure arises out of a Force Majeure Event.
- (b) On the occurrence of a Force Majeure Event, SSCC must promptly notify the Customer of the existence of the Force Majeure Event and the cessation or termination of the Force Majeure Event.

## **12. Assignment**

---

### **12.1 Transfer or Assignment by Customer**

The Customer may not, at any time during the Term, re-lease, sublease, swap, assign, transfer, novate, mortgage, charge, encumber or otherwise deal with any of its Leased Capacity or any its rights and obligations under this Agreement, or attempt or purport to do so, without the prior written consent of SSCC (which consent may not be unreasonably withheld or delayed).

### **12.2 Assignment by SSCC**

SSCC may assign, transfer, novate, mortgage, charge, encumber or otherwise deal with any of its rights or obligations under this Agreement to:

- (a) any person which provides financing to SSCC (or any Related Body Corporate of such person), without the Customer's consent;
- (b) any Related Body Corporate of SSCC, without the Customer's consent; or
- (c) any other person, but only with the Customer's consent (which may not be unreasonably withheld or delayed) if the dealing is to be effective on or before to the Transfer Restriction Date or without the Customer's consent if the dealing is to be effective after the Transfer Restriction Date.

The Customer agrees to execute any documents as may be reasonably necessary to give effect to this clause 12.2 (including without limitation any novation agreement).

### **12.3 Subcontracting by SSCC**

SSCC may subcontract or delegate any of its obligations under this Agreement to any person. For the avoidance of doubt, such subcontracting or delegation will not relieve SSCC from any liability or obligation under this Agreement.

## **13. General**

---

### **13.1 Notices**

- (a) A notice or other communication required or permitted to be given by one party to another must be in writing and:
  - (i) delivered personally;

- (ii) sent by pre-paid mail (by air, if international) to the address of the addressee specified in this Agreement; or
- (iii) sent by facsimile transmission to the facsimile number of the addressee with acknowledgment of receipt from the facsimile machine of the addressee,

except that an invoice provided under this Agreement may be delivered by email to the email address of the addressee specified in this Agreement.

- (b) A notice or other communication is taken to have been given:
  - (i) if delivered personally, immediately upon delivery;
  - (ii) if mailed to an address within the same country, on the second Business Day after posting;
  - (iii) if mailed to an address within another country, on the tenth Business Day after posting; or
  - (iv) if sent by facsimile or email before 4pm on a Business Day at the place of receipt, on the day it is sent and otherwise on the next Business Day at the place of receipt.
- (c) A party may change its address for service by giving notice of that change in writing to the other party.
- (d) The parties' respective contact details for notification under this Agreement are as set out in the Parties section above.

### **13.2 Disputes**

- (a) A party must not start court proceedings about a dispute arising out of this Agreement unless it first complies with this clause, except:
  - (i) where a party seeks urgent injunctive relief; or
  - (ii) where the dispute relates to compliance with this clause.
- (b) A party claiming that a dispute has arisen must notify each other party giving details of the dispute.

- (c) Each party to the dispute must use its best endeavours to resolve the dispute within five Business Days following receipt of notice of the dispute or a longer period agreed by the parties to the dispute.
- (d) If the parties do not resolve the dispute under paragraph (c), the chief executive officer or other senior employee of each party must negotiate in good faith to resolve the dispute for a period of up to ten Business Days after the end of the period referred to in paragraph (c).
- (e) If the dispute is not resolved within the time specified in paragraph (d), or within such further period as the parties agree, then the parties must refer the dispute to mediation in accordance with the Alternative Dispute Resolution Act 2007 (Samoa).

### **13.3 Further Assurance**

Each party will from time to time do all things (including executing all documents) necessary or desirable to give full effect to this Agreement. Each party acknowledges that it has obtained legal advice, or had the opportunity to obtain legal advice, in connection with this Agreement.

### **13.4 Counterparts**

This Agreement may be executed in any number of counterparts each of which constitutes an original and all of which collectively, constitute only one agreement. The signatures of all of the parties need not appear on the same counterpart, and delivery of an executed counterpart signature page by facsimile is as effective as executing and delivering this Agreement in the presence of the other parties to this Agreement. This Agreement is effective upon delivery of one executed counterpart from each party to the other. This clause does not apply if counterpart signing is not required.

### **13.5 Survivability**

- (a) Subject to any provision to the contrary, this Agreement will enure to the benefit of and be binding upon the parties and their successors, trustees, permitted assigns or receivers but will not enure to the benefit of any other persons.
- (b) The covenants, conditions and provisions of this Agreement which are capable of having effect after the expiry or termination of this Agreement will remain in full force and effect following the expiry or termination of this Agreement.

- (c) Each indemnity in this Agreement survives the expiry or termination of this document.

### **13.6 Severance**

If any part of this Agreement is legally unenforceable, this Agreement does not include it. The remainder of this Agreement continues in full force.

### **13.7 Whole Agreement**

In relation to the subject matter of this Agreement this Agreement is taken to be the whole agreement between the parties and supersedes all oral and written communications by or on behalf of any of the parties in relation to the subject matter of the Agreement.

### **13.8 Relationship**

The parties agree that this Agreement does not create any relationship of partnership or employment, franchise, joint venture or agency and that SSCC is an independent contractor.

### **13.9 Governing Law**

This Agreement is governed by the laws of the Independent State of Samoa. Each party irrevocably submits to the non-exclusive jurisdiction of the courts of the Independent State of Samoa and the courts of appeal from them in respect of any disputes arising under or relating to this Agreement.

**Schedule 1**

**Capacity Lease Details**

**Part A**

<b>1. Name of Customer</b>			
<b>2. Capacity Payment Dates</b>	Payment in respect of the Leased Capacity shall be made monthly in advance (that is, prior to the first day of each month). SSCC may issue an invoice 20 Business Days before each such date.		
<b>3. Currency</b>	United States Dollars		
<b>4. RFS Date</b>	Expected to be		
<b>5. Payment Support</b>	Bank guarantee in favour of SSCC from a bank with credentials, and on terms, acceptable to SSCC and for an amount not less than the aggregate of the Capacity Payments for 12 months.		

**Part B**

	<b>Capacity Lease 1</b>	<b>Capacity Lease 2</b>	<b>Capacity Lease 3</b>	<b>Capacity Lease 4</b>
<b>6. Leased Capacity*</b>				
<b>7. Access Point A</b>				
<b>8. Access Point B</b>				
<b>9. Capacity Payment (per month ex VAGST)*</b>				
<b>10. Capacity Activation Date</b>				
<b>11. Initial Lease Term</b>				

<b>(months from the Capacity Activation Date)</b>				
<b>12. Renewal Lease Term</b>	Month-to-month following the Initial Lease Term until terminated by either party on not less than two months' notice.	Month-to-month following the Initial Lease Term until terminated by either party on not less than two months' notice.	Month-to-month following the Initial Lease Term until terminated by either party on not less than two months' notice.	Month-to-month following the Initial Lease Term until terminated by either party on not less than two months' notice.

\* **Note:** [SEE RIO FOR LIST OF SERVICES AND PRICING AVAILABLE TO CUSTOMERS]

## **Schedule 2**

### **SSCC Network Configuration and Specification**

[TBA]

### Schedule 3

#### Capacity Unavailability Credits

##### 1 Unavailability

SSCC does not warrant that the Leased Capacity will be available on an uninterrupted basis, as interruptions may occur outside the control of SSCC. SSCC will nevertheless use reasonable endeavours to ensure that any periods of unavailability are minimised and, in the event of a period of unavailability, may provide to the Customer a credit in accordance with this Schedule (“**Capacity Unavailability Credit**”). The Capacity Unavailability Credits described in this Schedule are the Customer’s sole and exclusive remedies for all matters related to any periods of unavailability. In this Schedule, a month is deemed to begin at 12:00AM Greenwich Mean Time (“**GMT**”) on the first day of a calendar month and end at 12:00AM GMT on the first day of the next calendar month (“**Month**”).

##### 2 Calculation

At the end of a Month in which the Customer requests a Capacity Unavailability Credit, SSCC will calculate the total amount of time that the Leased Capacity was unavailable (“**Capacity Unavailability Time**”), based on SSCC’s network records. The Capacity Unavailability Time will be used to determine any Capacity Unavailability Credit. The Capacity Unavailability Credit will be deducted from the Capacity Payment for the Leased Capacity in respect of the relevant Month, in the following amounts:

<b>Duration of unavailability of Leased Capacity in the Month (in minutes)</b>	<b>Capacity Unavailability Credit (percentage of the Capacity Payment for the Month)</b>
0–216	No credit
217 – 480	2%
Above 480	4%

##### 3 Exclusions

The calculation of Capacity Unavailability Credit amounts will not include periods of any outage or unavailability or other degradation of the Leased Capacity associated with or caused (in whole or part) by or attributable to any of the following:

- (a) a planned outage;
- (b) planned maintenance during which an outage occurs;
- (c) a cable cut on the SSCC Network (which was not caused by or contributed to by the fault or negligence of SSCC);
- (d) an outage on any non-physically diverse or non-redundant terrestrial section of the SSCC Network;
- (e) an outage on any local access, local loop or domestic backhaul facility ordered directly by the Customer or provided by SSCC on a pass-through basis;
- (f) an outage on any Carrier Capacity;
- (g) any act or omission of the Customer or the Customer's agents, contractors, or vendors;
- (h) Customer provided power, equipment or facilities; or
- (i) a Force Majeure Event.

#### **4 Application of credit**

SSCC will calculate the amount of any applicable Capacity Unavailability Credit and deduct this amount from the invoice for the Capacity Payment next issued by SSCC after the end of the Month in which the Capacity-affecting event occurred. Capacity Unavailability Credits are calculated after deduction of all discounts and other special pricing arrangements, and may not be applied to governmental fees, taxes, VAGST, surcharges, local access charges or any other charges other than Capacity Payments.

#### **5 Other conditions**

If the Customer is entitled to receive more than one Capacity Unavailability Credit due to the same Capacity-affecting event, the Customer will only receive the largest possible credit that it would otherwise be entitled to receive. In no event will the total amount of Capacity Unavailability Credits issued to the Customer for a Month exceed ten percent (10%) of the Capacity Payment invoiced to the Customer for the affected Capacity for that Month.

**Schedule 4**

**Special Conditions**

Nil.

**SIGNED** by the parties as an agreement.

**SIGNED** for **Samoa Submarine Cable Company Limited** by its duly authorised representative, in the presence of:

---

Signature of witness

---

Signature of representative

---

Name of witness (print)

---

Name/title (print)

**SIGNED** by [ **Customer legal name** ]  
by its duly authorised  
representative, in the presence of:

---

Signature of witness

---

Signature of representative

---

Name of witness (print)

---

Name/title (print)



## NETWORK

## ACCESS GUIDELINES

VERSION 5

Guidelines for access to the SSCC Network at designated access points and an overview of the locations of access points

These Access Guidelines (including the locations and addresses for access points) are subject to change from time to time.

## Contents

1. Introduction	1
2. Summary of Connections and Capacity	2
3. Connectivity and Access Description	3
4. Capacity Access Points (CAPs)	6
5. Capacity Services and Termination Options	8
6. SSCC Access	9
7. SSCC Cable Capacity Access in Apia and Suva	10
8. Tui-Samoa : Network Configuration and Specification	11
9. Tui-Samoa System Connectivity	12
10. SSCC Cable Landing Station Details	14

# Samoa Submarine Cable

## 1 Introduction

Samoa Submarine Cable Company Limited ("SSCC") has established international submarine cable connectivity, linking Apia (Samoa), Suva (Fiji), Sydney (Australia), and the West Coast (USA), as well as domestic submarine cable connectivity between Apia and Tuasivi (Savaii, Samoa), through the SSCC Network. This network includes the Tui-Samoa cable (TS).

Access to the SSCC Network will be facilitated through designated Capacity Access Points ("CAPs") strategically located in Apia, Suva, Sydney, Hawaii, San Jose, and Los Angeles. These SSCC CAPs are optimally situated for the convenience of SSCC customers. Authorized customers can utilize SSCC cable capacity services.

This document offers an overview of the currently available locations and will be periodically updated to reflect the growth and changes in the number of access points. Any terms not explicitly defined within this document can be referred to in the Capacity Purchase Agreement or Capacity Lease Agreement established between SSCC and the Customer.

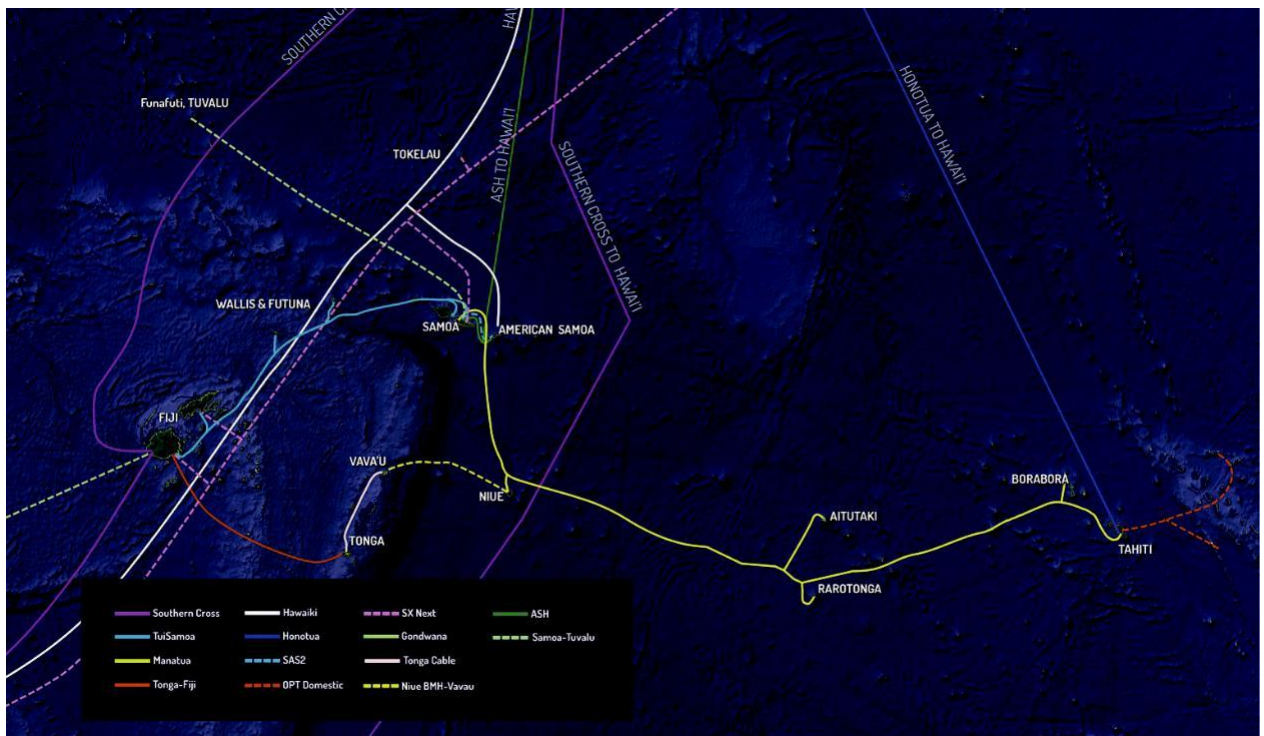

### 2 Summary of Connections and Capacity

The SSCC Network supports various connections and capacities:

- A 100G wavelength of capacity links Apia and Suva.
- A 100G wavelength of capacity links Apia and Tuasivi.
- A 100G wavelength of capacity links SSCC Vaivase-tai CLS to the Fintel CLS Suva in order to interconnect to the SSCN Network with (“CAPs”) in Sydney, Hawaii, San Jose and LA West Coast USA.
- A 100G wavelength of capacity links SSCC Vaivase-Tai CLS to Manatua CLS (Taravao), French Polynesia.
- Terrestrial backhaul links the Manatua CLS (Taravao) to Honotua CLS (Papenoo) French Polynesia in order to link to Honotua CLS (Spencer Beach (Kawaihae), Big Island, Hawaii) then onwards to the West Coast USA via a third-party cable systems (SEA US)
- All capacity utilization within the SSCC Network will be facilitated through a CAP.

The specific access points for customers are as follows:

- In Apia, Customers will directly access capacity from the SSCC Cable Landing Station situated in Vaivase-Tai (Apia CAP).
- In Tuasivi, Customers will access capacity through interconnection with the SSCC Tuasivi CLS located southeast of the hospital (Tuasivi CAP).
- In Suva, Customers will access capacity through interconnection at the FINTEL Cable Landing Station (Suva CAP).
- In Sydney, Australia, Customers will access capacity at the Equinix Data Centre facility, located in Sydney (SYD1 CAP).
- In the West Coast USA, Customers can access capacity at the Coresite Data Centre facility in San Jose (SV1 CAP).
- Furthermore, in the West Coast USA, Customers can access capacity at the Coresite Data Centre facility in Los Angeles (LA2 CAP).

The primary service offered by SSCC between CAPs is Ethernet connectivity.

## 3 Connectivity and Access Description

SSCC offers comprehensive connectivity services, linking Samoa, Fiji, Australia, and the USA. In addition, SSCC facilitates connectivity between Samoa and the Honotua International cable system:

### 3.1 SSCC Cable Capacity Access in Australia

#### Sydney – Alexandria CLS (SY1) Equinix Data Centre Capacity

The capacity offered for the Sydney – Alexandria (SY1) Equinix Data Centre comprises various components, as outlined below:

##### **Uncontended SSCC Capacity (Samoa to Fiji):**

This component represents uncontended capacity provided by SSCC, facilitating secure and high-quality data transport between Samoa and Fiji.

##### **Uncontended SCCN Capacity (Fiji to Samoa, active + backup route):**

Uncontended SCCN capacity extends from Fiji to Samoa, encompassing both an active and a backup route. This capacity ensures robust connectivity between these two points.

##### **Backhaul from Alexandria Cable Landing Station in Sydney (SY1) to Equinix Data Center:**

The backhaul component establishes a connection from the Alexandria Landing Station in Sydney (SY1) to the Equinix Data Center. This connection is designed to ensure efficient data transfer and network connectivity.

##### **IP Transit (Equinix Sydney):**

The IP Transit service, offered within Equinix Sydney, provides uncontended Internet Protocol (IP) connectivity. This service contributes to enhanced network accessibility and data transmission.

The high-level network diagram illustrates the architectural arrangement of the system, showcasing the connections and relationships between the aforementioned components. It provides a visual representation of how the various elements interconnect to ensure seamless data transport and connectivity.

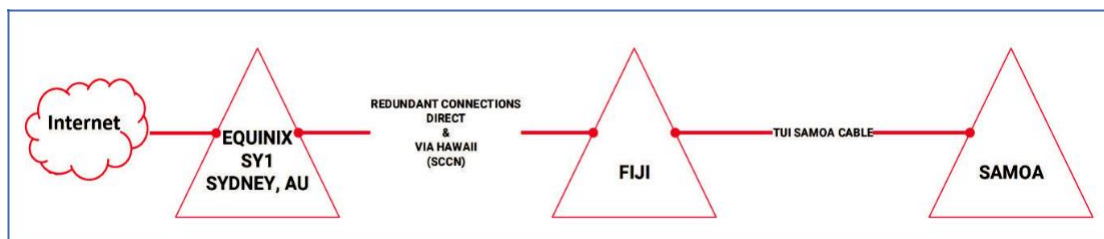

## Samoa Submarine Cable

### Total Latency and Service Levels

The total latency of the system from Samoa to the internet via Sydney is guided by the following targets:

#### Service Levels:

Sr. #	KPI	Description	Target
1	Latency	The latency is targeted to be less than or equal to 100 milliseconds (msec).	=<100 msec
2	Jitter	The jitter is aimed to be less than or equal to 10 milliseconds (msec).	=<10msec
3	Packet Loss	The packet loss is expected to be less than 0.5%.	<0.5%

It is important to note that the latency target applies to the SCCN primary path (Fiji to Australia segment). In the event that traffic switches to the backup path (Fiji – Hawaii – NZ and Australia), the latency is estimated to be around 100 milliseconds (msec). The primary route from Fiji to Sydney is typically operational more than 99.9% of the time.

Additionally, customers in Sydney and USA have established direct peering connections with some of their partners. This arrangement allows traffic to take the optimal route, often bypassing the public internet route. This approach is anticipated to enhance the end-user experience for traffic directed towards these partner services, contributing to improved service quality and reliability.

### IXP Access in Sydney as part of IP Transit Services

As part of the IP transit services, the IXP (Internet Exchange Point) access in Sydney encompasses connections to several key partners: Apple, Equinix IXP, Facebook (Meta), Google, LinkedIn, Netflix

These IXP connections provide direct access to major online platforms and services, enabling efficient and optimized data exchange.

## 3.2 SSCC Cable Capacity Access in USA

### SSCN Capacity and Interconnection

SSCC possesses capacity on the Southern Cross Cable Network (SSCN) that links Fiji to the West Coast of the USA. In Fiji, direct interconnection links SSCC to the SSCN. Initially, this interconnection extends a 10G submarine cable capacity from the SSCC Capacity Access Point (CAP) in Apia to the SSCC CAP in San Jose's SV1 Building.

## Samoa Submarine Cable

SSCN terminates at SV1, a facility owned and operated by Coresite at 55 South Market. At SV1, Customers have the opportunity to establish direct connections to a diverse array of IP service and content providers.

### LA2 (Coresite) USA Restoration Capacity - via Manatua Cable

#### **Uncontended Manatua Cable Capacity to CLS Taravao including Backhaul to CLS Papeoo (Samoa to French Polynesia):**

This component encompasses uncontended capacity via the Manatua cable, extending to the Manatua CLS (Taravao), French Polynesia. Additionally, there is domestic backhaul connectivity to the Honotua CLS (Papeoo) French Polynesia, ensuring robust connectivity between Samoa and French Polynesia.

#### **Uncontended Honotua Cable to Spencer Beach (Kawaihae) Hawaii then Onwards to LA2/Coresite via SXN (French Polynesia to Hawaii then Onwards to Los Angeles):**

Uncontended capacity is offered through the Honotua cable, extending to Honotua CLS (Spencer beach (Kawaihae), Hawaii) then onwards to the West Coast USA via Sea-US cable system. This connection spans from French Polynesia to Hawaii and then onwards to Los Angeles.

#### **TERESTIAL Backhaul from Morro Bay Landing Station in Los Angeles to LA2 CoreSite Data Center:**

Backhaul connectivity is established from the Morro Bay Landing Station in Los Angeles to the CoreSite Data Center. This connection contributes to efficient data transfer and network accessibility.

#### **IP Transit:**

The IP Transit service is offered, contributing to uncontended Internet Protocol (IP) connectivity.

### 3.3 Domestic Connectivity

#### **Samoa - Tuasivi Route:**

Within Samoa, the SSCC network offers domestic connectivity between Apia and Tuasivi (Savaii). This domestic route strengthens communication within the country, enabling efficient data sharing and connectivity for local communities.

### 4 Capacity Access Points (CAPs)

SSCC has positioned Capacity Access Points (CAPs) at key locations to enable straightforward access to its network services. These access points serve as gateways for customers to harness the capabilities of the SSCC network. The locations of these CAPs are as follows:

**Apia CAP:** Positioned at the SSCC Cable Landing Station in Vaivase-Tai, this access point provides direct access to the network in the capital city of Samoa, Apia.

**Tuasivi CAP:** Located southeast of the hospital, the Tuasivi CAP facilitates connectivity for customers seeking access to the network in the Savaii region.

**Suva CAP:** Situated at the FINTEL Cable Landing Station in Suva, Fiji, the Suva CAP offers a gateway to the SSCC network for customers in Fiji.

**SYD1 CAP:** Based in the Equinix Data Centre facility in Sydney, Australia, the SYD1 CAP serves as a connection point for customers seeking network access in Australia.

**SV1 CAP:** Located at the Coresite Data Centre facilities in San Jose, USA, LA2 CAPs enable customers to tap into the SSCC network in the United States.

**LA2 CAP:** Located at the Coresite Data Centre facilities in LA2.

Both SV1 and LA2 - CAPs enable customers to tap into the SSCC network in the United States.

Diagram 1 :

SSCC Network Diagram of system from Samoa to Sydney, LA  
(Tui-Samoa, SCCN, Manatua)

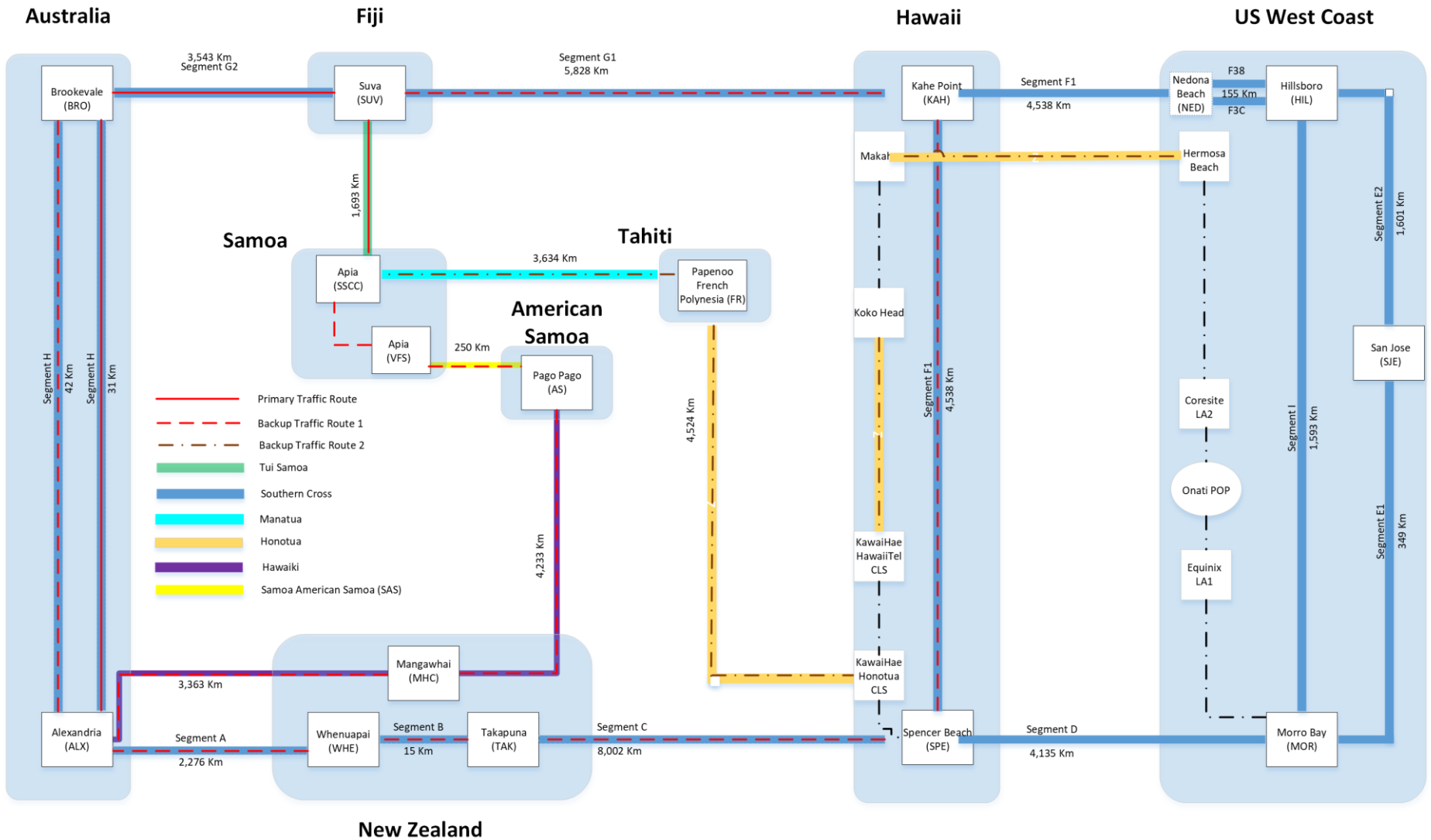

## 5 Capacity Services and Termination Options

The SSCC Network offers customers a range of capacity service options to suit their specific requirements:

### **Apia – Suva Termination:**

Customers can opt for capacity termination between Apia and Suva, facilitating seamless data exchange between these two locations.

### **Apia – Sydney Termination:**

Capacity services terminating between Apia and Sydney offer a direct link between Samoa and the Australian city of Sydney, enabling efficient communication and connectivity.

### **Apia – San Jose Termination:**

Customers seeking connectivity between Apia and San Jose can choose this termination option, establishing a connection to the West Coast of the USA.

### **4.4 Apia – Los Angeles Termination:**

This termination option provides capacity services connecting Apia to Los Angeles, offering a vital link to the larger network infrastructure in the USA.

### **Apia – Tuasivi Termination:**

For domestic connectivity within Samoa, customers can select this termination option, establishing a reliable connection between Apia and Tuasivi in Savaii.

Note: Customers aiming to transit Samoa for onward extension to SAS/ASH systems will essentially terminate their connection in Apia. They will need to coordinate appropriate domestic backhaul and interconnection arrangements with licensed network operators.\*

### **Capacity Offerings and Interface Options:**

Capacity services within the SSCC Network are provided as "leased services." The minimum capacity interface available is 100M Ethernet. Additionally, customers have the flexibility to choose from 1GigE and 10GigE interfaces. This dynamic capacity assignment allows customers to commit to a data speed of their preference within the limits of the chosen interface. Capacity can be delivered either electrically or optically, offering versatile options to cater to different technical requirements.

### **Further Information:**

For a more comprehensive understanding of SSCC's products and offerings, detailed information will be available in the SSCC Product Description. This document will undergo periodic reviews to ensure it remains up-to-date and aligned with the evolving needs of customers.

### & SSCC Access

SSCC operates as a NEUTRAL INTERNATIONAL CABLE CARRIER, ensuring that each Customer is provided with equal and optimal services. This neutrality guarantees that all eligible Customers can access the best connectivity directly from strategically located centers in Apia, Suva, Sydney, and the West Coast USA.

In general, the Customer bears the responsibility of accessing the SSCC Network Cable Interface at the designated CAP, aligned with the relevant Ethernet or Optical interface type and other technical requisites as updated over time. Customers must adhere to the processes and procedures for requesting and obtaining access to each Facility, which may vary across different Facilities.

SSCC facilitates reasonable access for the Customer or its approved third-party service provider (if sanctioned by SSCC) to the CAP. This access serves the purpose of enabling Customer testing of capacity, installation (if applicable), testing, operation, maintenance of the Customer's equipment, or any other reasonable use related to the Customer's capacity utilization.

SSCC offers access to the Optical Distribution Frame (ODF) within each CAP, permitting the Customer or their approved service provider to install an interconnect cable from the Cable Interface to another location within the same CAP. Unless agreed otherwise, SSCC will deliver capacity to the suitable interconnect point at each CAP, while the Customer assumes responsibility for interconnection costs, including cross-connect from the CAP interconnect point.

Subject to space limitations, SSCC may provide colocation and/or carrier interconnect space, connection facilities, and essential services to the Customer or its approved service provider. This additional service is presented separately under the Colocation Agreement or Carrier Interconnect Agreement provided by SSCC, adhering to the terms stipulated in those agreements.

### 7 SSCC Cable Capacity Access in Apia and Suva

SSCC owns and operates the Cable Landing Station (CLS) in Apia, Samoa. Collaboratively, SSCC has established landing party agreements for CLS facilities in Fiji with FINTEL and in French Polynesia with OPT (Onati) French Polynesia.

Upon request from an SSCC Customer, the Landing Party will allocate a reasonable amount of suitable space, connection facilities, and necessary services at the Cable Landing Station. This provision caters to purposes pertinent to the Customer's utilization of capacity on the SSCC Network, within the confines of space restrictions. The Landing Party grants the Customer the right to install their equipment within this space and access the equipment as agreed upon between the Landing Party and the Customer. Access to space, connection facilities, and necessary services is provided promptly, with fairness and without discrimination.

SSCC will endeavor to ensure that the Landing Party facilitates access to the Cable Stations in line with the stipulations of the respective landing party agreements.

## Samoa Submarine Cable

### ( Tui-Samoa : Network Configuration and Specification

**Apia (Samoa) - Mata-Utu (Wallis) - Suva (Fiji) Link:** This is a repeatered link with terminal stations located in Vaivase (Samoa), SPT Afala Mata'Utu (Wallis), and Fintel Suva station (Fiji). The land cable lengths are 1.3 km in Vaivase-tai, 3.5 km in Mata'Utu, and 250 m in Suva. The submarine cable lengths are 1410 km between Vaivase and Suva, 573 km between Vaivase and Mata'Utu, and M9M.1 km between Mata-Utu and Suva. The system comprises 2 fiber pairs, and more details about the fiber pairs' connections and capacities are provided.

**Apia (Samoa) - Tuasivi (Samoa) Link:** This unrepeatered link features terminal stations in Vaivase-Tai and Tuasivi, with land cable lengths of 1.3 km in Vaivase and 400 m in Tuasivi. The submarine cable length is 132 km, and the system consists of 1 fiber pair called fp3 equipped with 1 \* 100G.

### 9 Tui-Samoa System Connectivity

The Tui-Samoa system establishes connectivity between the following cities and countries:

**Repeatered Link - Apia (Samoa), Mata-Utu (Wallis), Suva (Fiji):**

This link involves repeatered connectivity between Apia (Samoa), Mata-Utu (Wallis), and Suva (Fiji).

**Unrepeatered Link - Apia (Samoa) and Tuasivi (Samoa):**

This link offers unrepeatered connectivity between Apia (Samoa) and Tuasivi (Samoa).

**Unrepeatered Link - Mata-Utu (Wallis) and Leava (Futuna):**

Unrepeatered connectivity is established between Mata-Utu (Wallis) and Leava (Futuna).

**Unrepeatered Link - Suva (Fiji) and Savusavu (Fiji):**

Unrepeatered connectivity is established between Suva (Fiji) and Savusavu (Fiji).

System Parameters:

**Repeatered Link - Apia, Mata-Utu, Suva:**

For the repeatered link between Apia, Mata-Utu, and Suva:

- Terminal stations are located in Vaivase (Samoa), SPT Afala Mata'Utu (Wallis), and Fintel Suva station (Fiji).
- Land cable length is 1.3 km in Vaivase-tai, 3.5 km in Mata'Utu, and 250 m in Suva.
- Submarine cable lengths include:
  - 1410 km between Vaivase and Suva.
  - 573 km between Vaivase and Mata'Utu.
  - M9M.1 km between Mata-Utu and Suva.
- - The system comprises 2 fiber pairs:
  - Fp1 is a direct fiber from Vaivase to Suva, with a connection through an OADM BU to Mata-Utu. This includes:
    - 1 \* 100G capacity between Vaivase and Suva.
    - 2 \* 100G capacity between Vaivase and Mata-Utu.
    - 2 \* 100G capacity between Suva and Mata-Utu.
  - Fp2 is a direct fiber from Vaivase-tai to Suva, designated as dark fiber.

# Samoa Submarine Cable

## Unrepeated Link - Apia and Tuasivi:

For the unrepeated link between Apia and Tuasivi:

- Terminal stations are located in Vaivase-Tai and Tuasivi.
- Land cable length is 1.3 km in Vaivase and 400 m in Tuasivi.
- Submarine cable length is 132 km.
- The system comprises 1 fiber pair called Fp3 equipped with a capacity of 1 \* 100G.

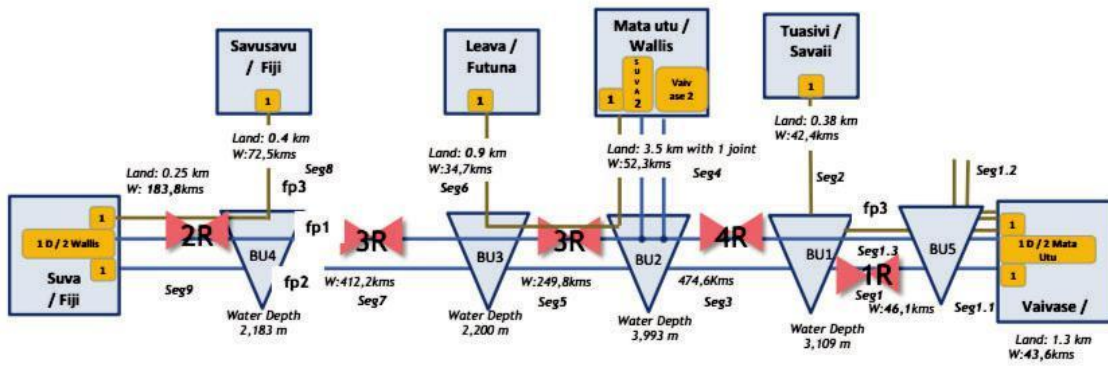

Leava & Mata utu ; 336,8 km / LC 4,4kms  
 Suva - Savusavu ; 256,3 km / LC 0,8 kms  
 Tuasivi - Vaivase ; 132,1 Kms / LC 1,7 kms  
 Suva - Vaivase ; 1409,7 kms / LC 1,5 kms

BU1, BU3, BU4/ BU5  
 BU2 Non-power switched full fibre drop BU NPS FFD / dedicated spare  
 Non-power switched fixed ratio OADM BU with connection to Suva and Apia / dedicated spare

— Repeated fibre pair (FP#1) Z-110-A-166-RR  
 — Un-Repeated fibre pair (FP#2) Z-110-A\_168-UR

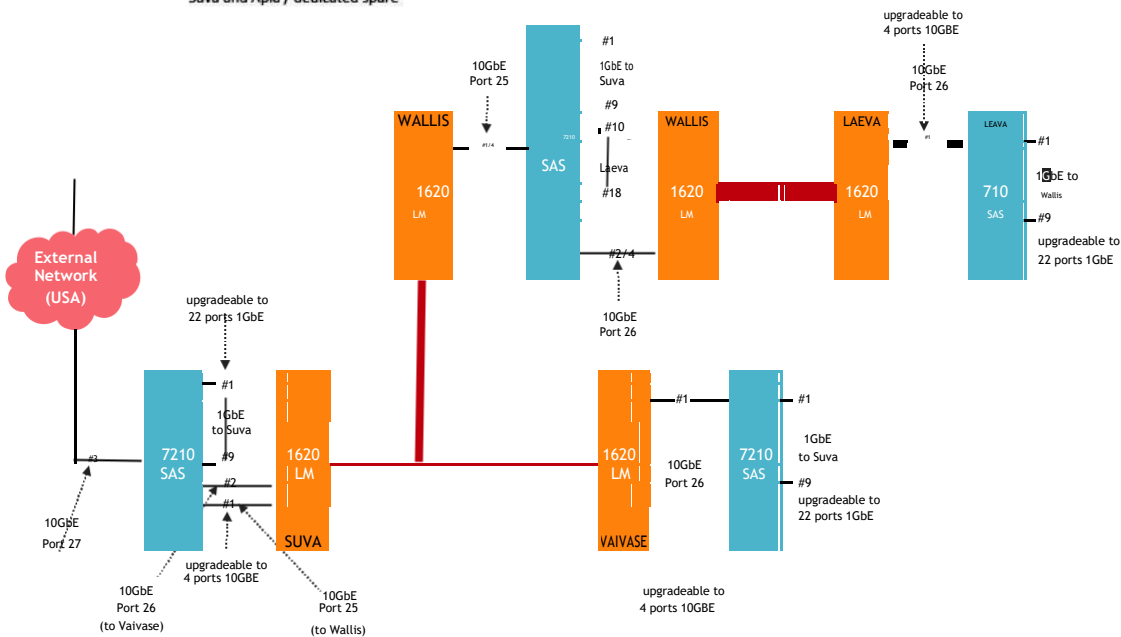

## 10 SSCC Cable Landing Station Details

The locations of the Cable Stations are as follows:

### SSCC CLS (Vaivase-Tai, Apia, SAMOA)



### Suva, Fiji

Fiji International Telecommunications  
Limited 151 Rifle Range Road, Vatuwaqa,  
Suva, Fiji Attention: George Samisoni  
Telephone: +K79 – 33000K5  
Facsimile: +K79 - 3300750



End of Access  
Guidelines

**SAMOA SUBMARINE CABLE COMPANY (SSCC)**

**REVISED REFERENCE INTERCONNECT OFFER (RIO)**

**1 JANUARY 2026**

**SAMOA SUBMARINE CABLE COMPANY LIMITED**  
**REFERENCE INTERCONNECT OFFER ATTACHMENT D**  
**SERVICES AND CHARGES BOOK**

**INTERNATIONAL CAPACITY LEASE AGREEMENT**

<p><b>Service:</b></p> <p>Tui-Samoa Cable  Capacity Lease - Tier 1 Wholesale Connectivity  - Samoa/Fiji:</p> <p>• Charges are based upon a combination of commitment term (columns) and amount of capacity (rows) specified in the table</p>	<p style="text-align: center;"><b>Charges</b>  Capacity payments including O&amp;M (charge per Mbps per month) (USD)</p> <p style="text-align: center;"><b>Charges per Mbps per month (US\$) - including O&amp;M</b></p> <table border="1" style="width: 100%;"> <thead> <tr> <th></th> <th style="text-align: center;">36 months</th> </tr> </thead> <tbody> <tr> <td style="text-align: center;"><b>300 Mbps</b></td> <td style="text-align: center;">44.00</td> </tr> <tr> <td style="text-align: center;"><b>500 Mbps</b></td> <td style="text-align: center;">35.00</td> </tr> <tr> <td style="text-align: center;"><b>1000 Mbps</b></td> <td style="text-align: center;">27.50</td> </tr> <tr> <td style="text-align: center;"><b>3000 Mbps</b></td> <td style="text-align: center;">24.00</td> </tr> <tr> <td style="text-align: center;"><b>5000 Mbps</b></td> <td style="text-align: center;">22.00</td> </tr> </tbody> </table>		36 months	<b>300 Mbps</b>	44.00	<b>500 Mbps</b>	35.00	<b>1000 Mbps</b>	27.50	<b>3000 Mbps</b>	24.00	<b>5000 Mbps</b>	22.00
	36 months												
<b>300 Mbps</b>	44.00												
<b>500 Mbps</b>	35.00												
<b>1000 Mbps</b>	27.50												
<b>3000 Mbps</b>	24.00												
<b>5000 Mbps</b>	22.00												

**DOMESTIC CAPACITY LEASE AGREEMENT**

<p><b>Service:</b></p> <p>Tui-Samoa Cable  Capacity Lease - Tier 1 Wholesale Connectivity  - Samoa/Fiji:  Domestic (Upolu/Savaii)</p> <p>• Charges are based upon a combination of commitment term (columns) and amount of capacity (rows) specified in the table</p>	<p style="text-align: center;"><b>Charges</b>  Capacity payments including O&amp;M (charge per Mbps per month) (USD)</p> <p style="text-align: center;"><b>Charges per Mbps per month (SAT\$) - including O&amp;M</b></p> <table border="1" style="width: 100%;"> <thead> <tr> <th colspan="2" style="text-align: center;">Minimum of 36 months</th> </tr> </thead> <tbody> <tr> <td style="text-align: center;"><b>Up to 1GB</b></td> <td style="text-align: center;">7.00</td> </tr> <tr> <td style="text-align: center;"><b>1GB - 2.5 GB</b></td> <td style="text-align: center;">6.00</td> </tr> <tr> <td style="text-align: center;"><b>2.5Gb to 5GB</b></td> <td style="text-align: center;">5.00</td> </tr> <tr> <td style="text-align: center;"><b>5GB to 7.5GB</b></td> <td style="text-align: center;">4.00</td> </tr> <tr> <td style="text-align: center;"><b>7.5GB to 10GB</b></td> <td style="text-align: center;">3.00</td> </tr> <tr> <td style="text-align: center;"><b>10GB +</b></td> <td style="text-align: center;">2.50</td> </tr> </tbody> </table>	Minimum of 36 months		<b>Up to 1GB</b>	7.00	<b>1GB - 2.5 GB</b>	6.00	<b>2.5Gb to 5GB</b>	5.00	<b>5GB to 7.5GB</b>	4.00	<b>7.5GB to 10GB</b>	3.00	<b>10GB +</b>	2.50
Minimum of 36 months															
<b>Up to 1GB</b>	7.00														
<b>1GB - 2.5 GB</b>	6.00														
<b>2.5Gb to 5GB</b>	5.00														
<b>5GB to 7.5GB</b>	4.00														
<b>7.5GB to 10GB</b>	3.00														
<b>10GB +</b>	2.50														

## INDEFEASIBLE RIGHT of USE (IRU)

<b>Service</b>	<b>Charges Capacity payments</b>	<b>Charges O&amp;M and other</b>
Tui-Samoa Cable Capacity IRU (10Gbps, 15 years) – Tier 1 Wholesale Connectivity – Samoa/Fiji/Sydney:	Charge (USD) \$12,000,000 (Quarterly Payments of one twelveth of the Base Price)	4% p.a.
<b>Service</b>	<b>Charges Capacity payments</b>	<b>Charges O&amp;M and other</b>
Tui-Samoa Cable Capacity IRU (20Gbps, 15 years) – Tier 1 Wholesale Connectivity – Samoa/Fiji/Sydney:	Charge (USD) \$15,120,000 (Quarterly Payments of one twelveth of the Base Price)	4%p.a.

### **Notes**

Cost-based pricing in accordance with SSCC's agreed governance procedures and policies.

All charges are in United States Dollars (except where otherwise stated) and exclusive of VAGST and other taxes and duties. See Capacity Lease Agreement (lease) and Capacity Purchase Agreement (IRU) for terms and conditions.